



LNA

Low-Noise Amplifier Series Installation and Operation Manual

IMPORTANT NOTE: The information contained in this document supersedes all previously published information regarding this product. Product specifications are subject to change without prior notice.

Errata A

Comtech EF Data Documentation Update

LNA

Low Noise Amplifier Series Installation and Operation Manual

Part Number MN/LNAS.IOM
Revision 0

Subject: Revise LNA Connector Pinout Table 2-1 and Overall Stability (Over Temperature) Specification

Date Per PLM System

Original Manual Part Number/Rev: MN/LNAS.IOM Rev 0

Errata Number/ PLM Document ID: ER-LNAS-EA0

PLM CO Number: C-0024188

Comments: *The information provided on Page 2 of 2 of this erratum will be incorporated into the next formal revision of the manual.*

1. Sect. 2.3 LNA Connector Pinouts (pg 2-2) – Replace Table 2-1:

Was:

4-pin LNA	6-pin LNA
A: Power Input	A: Power Input
B: This pin is reserved for oven voltage	B: GND
C: GND	C: FLT – Normally Closed
D: GND	D: FLT - Common
	E: FLT – Normally Open
	F: N/C

Change to:

Version	Connector Pinouts
4-pin LNA	A: Power Input B: GND C, D: Alarm
6-pin LNA – C-Band	A: Power Input B: GND C: FLT – Normally Closed D: FLT - Common E: FLT – Normally Open F: N/C
6-pin LNA – Ku-Band	A: Power Input B, C: GND D: FLT – Normally Closed E: Common F: FLT – Normally Open

2. Sect. 4.1 Summary of Specifications (pg 4-1) – Revise Overall Stability (Over Temperature) Specification:

Was:

Overall Stability (Over Temperature)	CLNA	KLNA
	± 1 dB over Full Band 0.40 dB p-p over 40 MHz	± 2 dB over Full Band 0.75 dB p-p over 40 MHz

Change to:

Overall Stability (Over Temperature)	CLNA	KLNA
	± 0.75 dB over Full Band 0.40 dB p-p over 40 MHz	± 1.5 dB over Full Band 0.75 dB p-p over 40 MHz



LNA

Low Noise Amplifier Series Installation and Operation Manual

Comtech EF Data is an ISO 9001
Registered Company

Part Number MN/LNAS.IOM
Revision 0
December 14, 2005



Copyright © Comtech EF Data, 2004. All rights reserved. Printed in the USA.
Comtech EF Data, 2114 West 7th Street, Tempe, Arizona 85281 USA, 480.333.2200, FAX: 480.333.2161

Customer Service

Contact the Comtech EF Data Customer Support Department for:

- Product support or training
- Information on upgrading or returning a product
- Reporting comments or suggestions concerning manuals

A Customer Support representative may be reached at:

Comtech EF Data
Attention: Customer Support Department
2114 West 7th Street
Tempe, Arizona 85281 USA

480.333.2200 (Main Comtech EF Data Number)
480.333.4357 (Customer Support Desk)
480.333.2161 FAX

or, E-Mail can be sent to the Customer Support Department at:

service@comtechefdata.com

Contact us via the web at www.comtechefdata.com.

To return a Comtech EF Data product (in-warranty and out-of-warranty) for repair or replacement:

- Request a Return Material Authorization (RMA) number from the Comtech EF Data Customer Support Department.
- Be prepared to supply the Customer Support representative with the model number, serial number, and a description of the problem.
- To ensure that the product is not damaged during shipping, pack the product in its original shipping carton/packaging.
- Ship the product back to Comtech EF Data. (Shipping charges should be prepaid.)

For more information regarding the warranty policies, see Warranty Policy, p. ix.

Table of Contents

CHAPTER 1. INTRODUCTION	1-1
1.1 INTRODUCTION	1-1
1.2 TECHNOLOGY	1-2
1.3 RELIABILITY	1-2
1.4 CONSTRUCTION.....	1-2
CHAPTER 2. INSTALLATION	2-1
2.1 UNPACKING.....	2-1
2.2 MOUNTING.....	2-2
2.3 LNA CONNECTOR PINOUTS	2-2
CHAPTER 3. FUNCTIONAL AND PHYSICAL DESCRIPTIONS	3-1
3.1 DIMENSIONAL ENVELOPE	3-1
3.1.1 C-Band LNA	3-1
3.1.2 Ku-Band LNA.....	3-2
CHAPTER 4. SPECIFICATIONS.....	4-1

Figures

Figure 1-1. LNA Low Noise Amplifier Series.....	1-1
Figure 1-2. LNA/710L Modulator Block Diagram	1-2
Figure 2-1. Installation of the Optional Mounting Bracket, KT/6228-2.....	2-3
Figure 3-1. Front Panel	3-2
Figure 3-2. Dimensional Envelope.....	3-3
Figure 4-1. Rear Panel.....	4-1
Figure 5-1. Front Panel View	5-1
Figure 5-2. Keypad.....	5-3
Figure 5-3. LNA Menu Trees.....	5-4
Figure 9-1. ASI And LVDS Interface Block Diagram	9-2
Figure 9-2. Rear Panel Layout.....	9-3
Figure 9-3. Signal Timing	9-5
Figure 10-1. 1000 Base-T Ethernet (GbE) Interface.....	10-1
Figure 10-2. GbE Interface Option Board – Phase 1	10-3

Tables

Table 4-1. Modem Rear Panel Connectorsfor 70/140 MHz Application.....	4-2
Table 4-2. Modem Rear Panel Connectorsfor L-Band Application.....	4-2
Table 5-1. Front Panel LED Indicators.....	5-2
Table 5-2. Summary of Alarms Reported for Tx and Unit Categories	5-26
Table 5-3. Summary of Live Alarms.....	5-28
Table 7-1. ITU Legacy and DVB-S2 Modes.....	7-7
Table 10-1. Interface Specifications.....	10-2
Table 10-2. Connector Pinout	10-4

Preface

About this Manual

This manual provides installation and operation information for the Comtech EF Data LNA Low Noise Amplifier Series. This is a technical document intended for earth station engineers, technicians, and operators responsible for the operation and maintenance of the LNA.

Conventions and References

Metric Conversion

Metric conversion information is located on the inside back cover of this manual. This information is provided to assist the operator in cross-referencing English to Metric conversions.

Cautions and Warnings



CAUTION indicates a hazardous situation that, if not avoided, may result in minor or moderate injury. CAUTION may also be used to indicate other unsafe practices or risks of property damage.



WARNING indicates a potentially hazardous situation that, if not avoided, could result in death or serious injury.



Indicates information critical for proper equipment function.

Reporting Comments or Suggestions Concerning this Manual

Comments and suggestions regarding the content and design of this manual will be appreciated. To submit comments, please contact the Comtech EF Data Technical Publications Department: techpub@comtechefdata.com

Electrical Safety

The LNA Low Noise Amplifier Series has been shown to comply with the following safety standard:

- EN 60950: Safety of Information Technology Equipment, including electrical business machines

The equipment is rated for operation over the range 100 - 240 volts AC. It has a maximum power consumption of 60 watts, and draws a maximum of 600 mA.



The user should observe the following instructions:

Fuses

The LNA is fitted with two fuses - one each for line and neutral connections. These are contained within the body of the IEC power inlet connector, behind a small plastic flap.

- For 115 and 230 volt AC operation, use T1.25A, 20mm fuses.

FOR CONTINUED OPERATOR SAFETY, ALWAYS REPLACE THE FUSES WITH THE CORRECT TYPE AND RATING.

Environmental

The LNA must not be operated in an environment where the unit is exposed to extremes of temperature outside the ambient range 0 to 50°C (32° to 122°F), precipitation, condensation, or humid atmospheres above 95% RH, altitudes (un-pressurized) greater than 2000 metres, excessive dust or vibration, flammable gases, corrosive or explosive atmospheres.

Operation in vehicles or other transportable installations that are equipped to provide a stable environment is permitted. If such vehicles do not provide a stable environment, safety of the equipment to EN60950 may not be guaranteed.





Installation

The installation and connection to the line supply must be made in compliance to local or national wiring codes and regulations.

The LNA is designed for connection to a power system that has separate ground, line and neutral conductors. The equipment is not designed for connection to power system that has no direct connection to ground.

The LNA is shipped with a line inlet cable suitable for use in the country of operation. If it is necessary to replace this cable, ensure the replacement has an equivalent specification. Examples of acceptable ratings for the cable include HAR, BASEC and HOXXX-X. Examples of acceptable connector ratings include VDE, NF-USE, UL, CSA, OVE, CEBEC, NEMKO, DEMKO, BS1636A, BSI, SETI, IMQ, KEMA-KEUR and SEV.

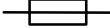
International Symbols:

Symbol	Definition		Symbol	Definition
	Alternating Current			Protective Earth
	Fuse			Chassis Ground

Telecommunications Terminal Equipment Directive

In accordance with the Telecommunications Terminal Equipment Directive 91/263/EEC, this equipment should not be directly connected to the Public Telecommunications Network.

EMC (Electromagnetic Compatibility)

In accordance with European Directive 89/336/EEC, the LNA Modem has been shown, by independent testing, to comply with the following standards:

Emissions: EN 55022 Class B - Limits and methods of measurement of radio interference characteristics of Information Technology Equipment.

(Also tested to FCC Part 15 Class B)

Immunity: EN 50082 Part 1 - Generic immunity standard, Part 1: Domestic, commercial and light industrial environment.

Additionally, the LNA has been shown to comply with the following standards:

EN 61000-3-2	Harmonic Currents Emission
EN 61000-3-3	Voltage Fluctuations and Flicker
EN 61000-4-2	ESD Immunity
EN 61000-4-4	EFT Burst Immunity
EN 61000-4-5	Surge Immunity
EN 61000-4-6	RF Conducted Immunity
EN 61000-4-8	Power Frequency Magnetic Field Immunity
EN 61000-4-9	Pulse Magnetic Field Immunity
EN 61000-4-11	Voltage Dips, Interruptions, and Variations Immunity
EN 61000-4-13	Immunity to Harmonics



In order that the Modem continues to comply with these standards, observe the following instructions:

- Connections to the Tx and Rx IF ports (Type N or Type F connectors) should be made using a good quality coaxial cable - for example 50 Ω or 75 Ω .
- All 'D' type connectors attached to the rear panel must have back-shells that provide continuous metallic shielding. Cable with a continuous outer shield (either foil or braid, or both) must be used, and the shield must be bonded to the backshell.
- The equipment must be operated with its cover on at all times. If it becomes necessary to remove the cover, the user should ensure that the cover is correctly re-fitted before normal operation commences.

Warranty Policy

This Comtech EF Data product is warranted against defects in material and workmanship for a period of two years from the date of shipment. During the warranty period, Comtech EF Data will, at its option, repair or replace products that prove to be defective.

For equipment under warranty, the customer is responsible for freight to Comtech EF Data and all related custom, taxes, tariffs, insurance, etc. Comtech EF Data is responsible for the freight charges **only** for return of the equipment from the factory to the customer. Comtech EF Data will return the equipment by the same method (i.e., Air, Express, Surface) as the equipment was sent to Comtech EF Data.

Limitations of Warranty

The foregoing warranty shall not apply to defects resulting from improper installation or maintenance, abuse, unauthorized modification, or operation outside of environmental specifications for the product, or, for damages that occur due to improper repackaging of equipment for return to Comtech EF Data.

No other warranty is expressed or implied. Comtech EF Data specifically disclaims the implied warranties of merchantability and fitness for particular purpose.

Exclusive Remedies

The remedies provided herein are the buyer's sole and exclusive remedies. Comtech EF Data shall not be liable for any direct, indirect, special, incidental, or consequential damages, whether based on contract, tort, or any other legal theory.

Disclaimer

Comtech EF Data has reviewed this manual thoroughly in order that it will be an easy-to-use guide to your equipment. All statements, technical information, and recommendations in this manual and in any guides or related documents are believed reliable, but the accuracy and completeness thereof are not guaranteed or warranted, and they are not intended to be, nor should they be understood to be, representations or warranties concerning the products described. Further, Comtech EF Data reserves the right to make changes in the specifications of the products described in this manual at any time without notice and without obligation to notify any person of such changes.

If you have any questions regarding your equipment or the information in this manual, please contact the Comtech EF Data Customer Support Department.

Chapter 1. INTRODUCTION

1.1 Introduction

The Comtech EF Data (CEFD) Low-Noise Amplifier (LNA) series (Figure 1-1) includes LNAs, available in C-Band and Ku-Band. They meet or exceed system requirements for commercial geosynchronous satellites worldwide. Their compact design and rugged construction make them ideal for transportable applications and severe environments. They have a comprehensive set of options to accommodate systems ranging from Very Small Amplifier Terminal (VSATs) to major earth stations.



C-Band Low-Noise Amplifier



Ku-Band Low-Noise Amplifier

Figure 1-1. LNA

1.2 TECHNOLOGY

The amplifiers incorporate both HEMT (High Electron Mobility Transistors) devices for Low-Noise temperature performance and GaAs FET (Gallium Arsenide) devices for low intermodulation. The unit uses surface mounted components for robotic manufacturing techniques, thereby insuring maximum product consistency and enhanced reliability.

1.3 RELIABILITY

The Comtech EF Data amplifier series (CLNA and KLNA) utilizes proprietary circuitry and high quality components to achieve an MTBF (mean time between failures) in excess of 160,000 hours. Each unit is subjected to a 72 hour burn-in and temperature cycled from -40 to 140°F (-40 to +60°C).

1.4 CONSTRUCTION

The LNAs (CLNA and KLNA) are housed in waterproof enclosures with a small profiles to better accommodate redundancy configurations. The enclosures also provide a pressurizable, integral waveguide flange.

Chapter 2. INSTALLATION

2.1 Unpacking

Inspect shipping containers for damage. If shipping containers are damaged, keep them until the contents of the shipment have been carefully inspected and checked for normal operation.

The modulator and manual are packaged in pre-formed, reusable, cardboard cartons containing foam spacing for maximum shipping protection.



Do not use any cutting tool that will extend more than 1 inch into the container. This can cause damage to the LNA.

Unpack the LNA as follows:

Step	Procedure
1	Cut the tape at the top of the carton indicated by OPEN THIS END.
2	Remove the cardboard/foam space covering the LNA.
3	Remove the LNA, and manual from the carton.
4	Save the packing material for storage or reshipment purposes.
5	Inspect the equipment for any possible damage incurred during shipment.
6	Check the equipment against the packing list to ensure the shipment is correct.
7	Refer to the following sections for further installation instructions.

2.2 Mounting

No special tools are required.

2.3 LNA Connector Pinouts

LNA can be supplied with the following connector configurations, depending on the model and options:

- 4 pin
- 6 pin

See Table 2-1 for pinouts of the above connectors.

Table 2-1. LNA Connector Pinouts

4-Pin LNA	6-Pin LNA
A: Power Input	A: Power Input
B: This pin is reserved for oven voltage	B: GND
C: GND	C: FLT – Normally Closed
D: GND	D: FLT – Common
	E: FLT – Normally Open
	F: N/C

Chapter 3. FUNCTIONAL AND PHYSICAL DESCRIPTIONS

3.1 Dimensional Envelope

All dimensions are in English units (centimeters are in parentheses).

3.1.1 C-Band LNA

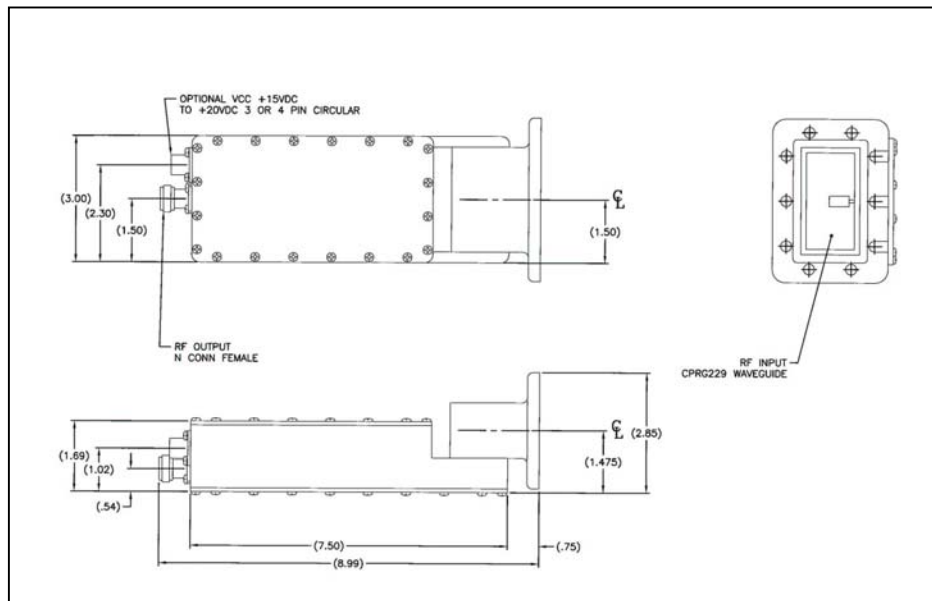

Figure 3-1. C-Band LNA Dimensions

3.1.2 Ku-Band LNA

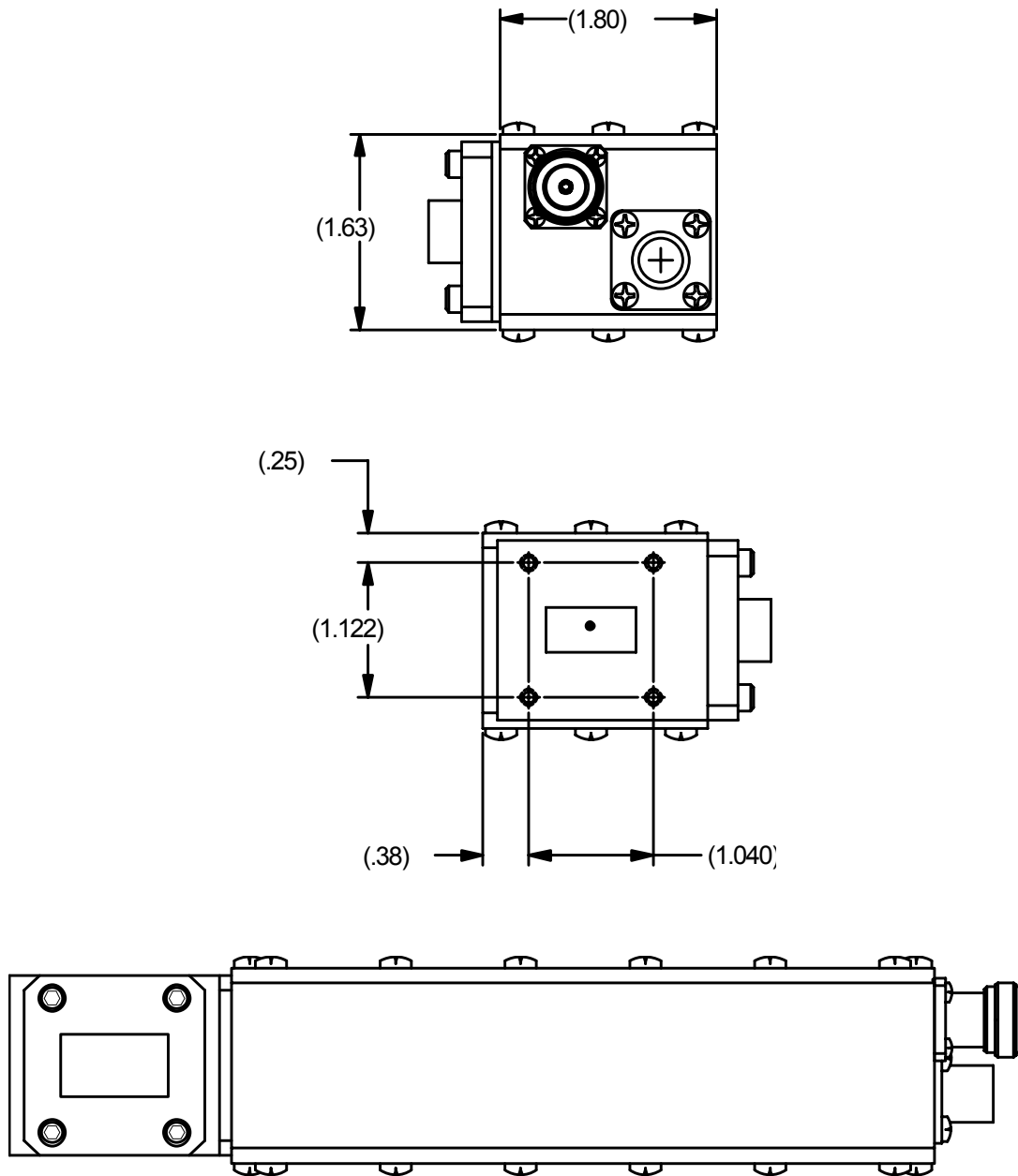

Figure 3-2. Ku-Band LNA Dimensions

Chapter 4. SPECIFICATIONS

4.1 Summary of Specifications

Frequency	CLNA 3.4 to 4.2 GHz 3.625 to 4.2 GHz 4.5 to 4.8 GHz	KLNA 10.95 to 12.75 GHz
Noise Temperature	CLNA 30, 35, 40, 45K	KLNA 80, 85K
Gain	50, 60 dB	
Overall Stability (Over Temperature)	CLNA ± 1 dB over Full Band 0.40 dB p-p over 40 MHz	KLNA ± 2 dB over Full Band 0.75 dB p-p over 40 MHz
Level @ 1 dB Comp.	+10 dBm	
Third Order Intercept	+20 dBm	
AM-PM Conversion	0.5°/dB @ -5 dBm	
Linear Group Delay	0.01 ns/MHz	
Parabolic Group Delay	0.001 ns/MHz ²	
Ripple	0.1 ns p-p	
Input/Output VSWR	1.25:1 max.	
Input Waveguide	CLNA CPR229	KLNA WR75
Output Connector	Type N Standard, Optional SMA	
Operating Temp.	-40 to +140°F (-40 to +60°C)	
Input Power	+12 to +24 VDC @ 120 mA	
Power Connector	CLNA Coaxial or PTA02A-9-4P	KLNA Coaxial and 4-Pin

METRIC CONVERSIONS

Units of Length

Unit	Centimeter	Inch	Foot	Yard	Mile	Meter	Kilometer	Millimeter
1 centimeter	—	0.3937	0.03281	0.01094	6.214×10^{-6}	0.01	—	—
1 inch	2.540	—	0.08333	0.2778	1.578×10^{-5}	0.254	—	25.4
1 foot	30.480	12.0	—	0.3333	1.893×10^{-4}	0.3048	—	—
1 yard	91.44	36.0	3.0	—	5.679×10^{-4}	0.9144	—	—
1 meter	100.0	39.37	3.281	1.094	6.214×10^{-4}	—	—	—
1 mile	1.609×10^5	6.336×10^4	5.280×10^3	1.760×10^3	—	1.609×10^3	1.609	—
1 mm	—	0.03937	—	—	—	—	—	—
1 kilometer	—	—	—	—	0.621	—	—	—

Temperature Conversions

Unit	° Fahrenheit	° Centigrade
32° Fahrenheit	—	0 (water freezes)
212° Fahrenheit	—	100 (water boils)
-459.6° Fahrenheit	—	273.1 (absolute 0)

Formulas
$C = (F - 32) * 0.555$
$F = (C * 1.8) + 32$

Units of Weight

Unit	Gram	Ounce Avoirdupois	Ounce Troy	Pound Avoir.	Pound Troy	Kilogram
1 gram	—	0.03527	0.03215	0.002205	0.002679	0.001
1 oz. avoir.	28.35	—	0.9115	0.0625	0.07595	0.02835
1 oz. troy	31.10	1.097	—	0.06857	0.08333	0.03110
1 lb. avoir.	453.6	16.0	14.58	—	1.215	0.4536
1 lb. Troy	373.2	13.17	12.0	0.8229	—	0.3732
1 kilogram	1.0×10^3	35.27	32.15	2.205	2.679	—



2114 WEST 7TH STREET TEMPE ARIZONA 85281 USA
480 • 333 • 2200 PHONE
480 • 333 • 2161 FAX