

800W Ku-Band BUC/ SSPB/ SSPA Second Generation GaN Technology

SSPA
SSPB (BUC)

AWMAg-K
SSPBMg-K

5200-SapphireBlu™ series
5200-SapphireBlu™ series

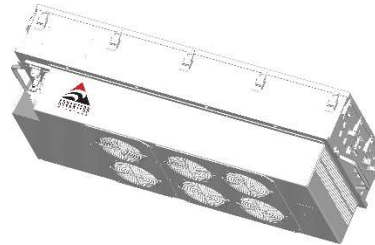

1:2 Redundant Version

UltraLinear™ SapphireBlu™

- High power density in a compact, rugged, weatherproof package
- UltraLinear™, designed for Multi Carrier Operations
- High Performance GaN Technology SSPA Outdoor design concept
- High Reliability, High Linearity, Low Energy Consumption

The Ultimate Solution for Direct to Home TV

- Save 8 to 10 dB power compared to Indoor Klystron
- Save Millions of dollars in Energy Cost, Satellite Bandwidth, CAPEX
- Can cover multiple transponders, full DVB-S2 enabled
- Rugged, Weatherproof Outdoor Package,
- MIL-STD-188-164A Compliant
- Redundant Ready, Power Expandable to
- 3 kW by phase combining

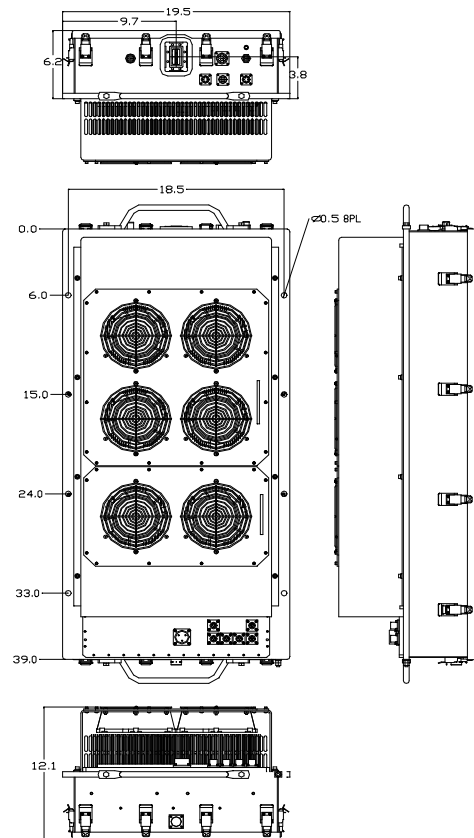

- Exceeds all barriers between Klystrons, TWTs and SSPAs
- We can now saturate all transponders of an entire satellite and obtain maximum bandwidth/power efficiency (using modular RF concept)
- 2 years warranty, due to increased GaN Technology reliability
- Backed by over 25 years of Outdoor SSPA design and manufacturing

800W Ku-Band BUC/ SSPB/ SSPA Second Generation GaN Technology

Specifications	KS / KX
Operating Frequency	14.0 – 14.5 GHz (KS) / 13.75 – 14.5 GHz (KX)
L-Band input (BUC)	950 – 1450 MHz (KS) / 950 – 1700 MHz (KX)
Output Power	800W
P _{SAT}	+59.0 dBm typ.
P _{LINEAR}	+55.5 dBm minimum
	P _{LINEAR} is the power at which the IMD=-25 dBc for two CW signals 5 MHz apart, and the spectral regrowth is <-30 dBc @ 1.0 x symbol rate for a single QPSK/OQPSK/8PSK signal.
Gain	SSPA 68 ± 3 dB SSPB (BUC) 78 ± 3 dB
Gain adjustment range	20 dB in 1.0 dB steps
Gain flatness over full band	SSPA 2dB p-p max SSPB (BUC) 3 dB p-p max (KS); 4dB p-p (KX)
Gain slope over 40 MHz	± 0.3 dB max SSPB (BUC) ± 0.5 dB max
Gain variation over temperature	± 1.5 dB max
Input Impedance and VSWR	50 Ω SSPA 1.3:1 SSPB (BUC) 1.4:1
Output VSWR	1.3:1
Noise power density	-70 dBm/Hz in Transmit Band, -145 dBm/Hz in Receive Band (10.95 GHz – 12.75 GHz)
Spurious at P _{LINEAR}	SSPA: -65 dBc max SSPB (BUC): -55 dBc max
Harmonics	-50 dBc @ P _{LINEAR}
AM/PM conversion	<1.0°/dB P _{LINEAR}
Third order IMD (two tones)	< -25 dBc two tones 5 MHz apart at P _{linear}
Group delay	1 nsec p-p max over any 40 MHz band
Residual AM Noise	0 – 10 kHz -45 dBc 10 kHz – 500 kHz -20 (1.25 + log F) dBc F = Frequency in kHz 500 kHz – 1 MHz -80 dBc
SSPB (BUC)	
Local Oscillator freq.	13.05 GHz (KS) / 12.8 GHz (KX)
Internal Reference frequency (optional)	10 MHz Aging/day ±2 × 10 ⁻¹⁰ Aging/year ±5 × 10 ⁻⁸ Stability ±2 × 10 ⁻⁸ over temp range
Phase Noise	-53 dBc/Hz at 10Hz -83 dBc/Hz at 10 kHz -63 dBc/Hz at 100Hz -93 dBc/Hz at 100 kHz -73 dBc/Hz at 1000Hz
External Reference Frequency phase noise (max)	10 MHz -155 dBc/Hz at 10 kHz -120 dBc/Hz at 10Hz -160 dBc/Hz at 100 kHz -135 dBc/Hz at 100Hz -150 dBc/Hz at 1000Hz
Weight & Dimensions	
Dimensions	L x W x H 39.00" x 18.50" x 12.10" (990 x 470 x 307 mm)
Weight	275 lbs (125 kg)
AC input voltage	190 – 265 VAC (47-63 Hz)
Power consumption	3.5kW at 53 dBm 5kW at P _{LINEAR} 6.0kW at P _{SAT}
Interfaces	Input (RF or L-Band) - N type female AC line - MS3102 type Output Sample Port - N type female RF output - WR75 Cover RS485/Ethernet MS3112 type
Environmental	Temperature Operating -30°C to +55 °C Option 1 -40°C to +55 °C Option 2 -50°C to +50 °C Storage -55°C to +85 °C Humidity 100% condensing Altitude 10,000' AMSL, derated by 2 °C/1000' from AMSL

Ref.: PB-SAPPH-2G-Ku-800W-22245

NORTH AMERICA

USA
info.usa@advantechwireless.com

CANADA
Info.canada@advantechwireless.com

EUROPE

UNITED KINGDOM
info.uk@advantechwireless.com

SOUTH AMERICA

info.latam@advantechwireless.com

BRAZIL
info.brazil@advantechwireless.com

ASIA

info.asia@advantechwireless.com

INDIA
info.india@advantechwireless.com