

wideye™

liberating communications

SYSTEM USER  
GUIDE BOOK  
REV 2.0

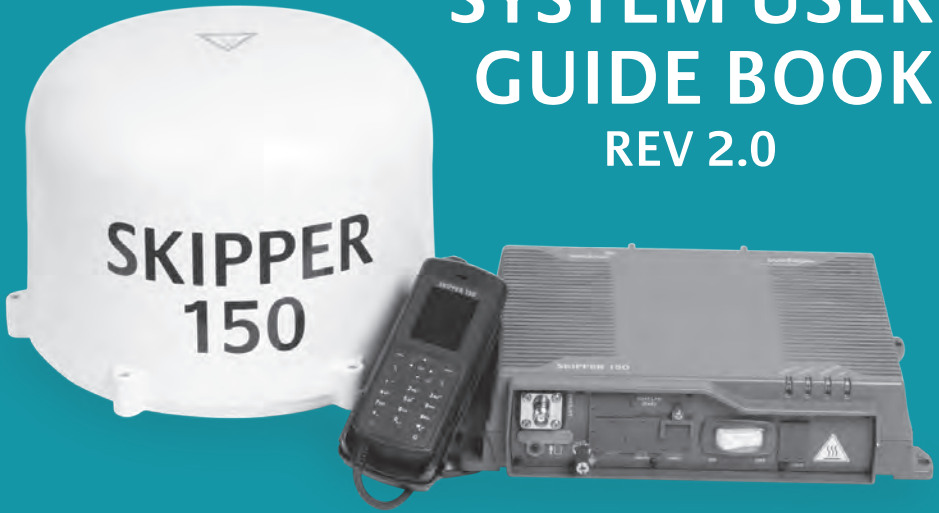

SKIPPER™  
150

inmarsat 

# Table of Contents

- Prefix** ..... 1
  
- Chapter 1**
  - Introduction ..... 7
  
- Chapter 2**
  - Getting Started ..... 13
  
- Chapter 3**
  - Using the Primary Handset ..... 22
  
- Chapter 4**
  - Using the Web Console ..... 56
  
- Chapter 5**
  - Connecting Devices with SKIPPER™ 150 UE ..... 98
  
- Chapter 6**
  - Installation of ADU ..... 100
  
- Chapter 7**
  - Installation of BDU ..... 105
  
- Chapter 8**
  - Troubleshooting and FAQs ..... 112
  
- Appendix A** ..... A-1

# Prefix

## Federal Communication Commission Notice

**FCC Identifier: QY9-SKIPPER150WE**

### **USE CONDITIONS:**

This device complies with part 15 of the FCC Rules. Operation is subject to the following two conditions:

1. This device may not cause harmful interference, and
2. This device must accept any interference received, including interference that may cause undesired operation.

### **NOTE:**

**This equipment has been tested and found to comply with the limits for a Class B digital device, pursuant to Part 15 of the FCC Rules. These limits are designed to provide reasonable protection against harmful interference in a residential installation. This equipment generates, uses and can radiate radio frequency energy and, if not installed and used in accordance with the instructions, may cause harmful interference to radio communications. However, there is no guarantee that interference will not occur in a particular installation.**

If this equipment does cause harmful interference to radio or television reception, which can be determined by turning the equipment off and on, the user is encouraged to try to correct the interference by one of the following measures:

- Reorient or relocate the receiving antenna.
- Increase the separation between the equipment and receiver.
- Connect the equipment into an outlet on a circuit different from that to which the receiver is connected.
- Consult the dealer or an experienced radio/TV technician for help.

### **IMPORTANT NOTE: EXPOSURE TO RADIO FREQUENCY RADIATION**

This Device complies with FCC & IC radiation exposure limits set forth for an uncontrolled environment. The Antenna used for this transmitter must be installed to provide a separation distance of at least 100cm from all persons and must not be co-located or operating in conjunction with any other antenna or transmitter.

### **FCC CAUTION:**

Any Changes or modifications not expressly approved by the manufacturer could void the user's authority, which is granted by FCC, to operate this satellite FleetBroadband SKIPPER 150 system.

## Industry Canada Statement:

### IC Identifier:5023A-FB150WE

This device complies with Radio standard specification RSS -170 of Industry Canada Rules. Operation is subject to the following two conditions:

1. This device may not cause harmful interference, and
2. This device must accept any interference received, including interference that may cause undesired operation.

### **IMPORTANT NOTE: Radiation Exposure Statement**

**This equipment complies with IC radiation exposure limits set forth for an uncontrolled environment. This antenna used for this transmitter must be installed to provide a separation distance of at least 100cm from all persons and must not be co-located or operating in conjunction with any other antenna or transmitter.**

## EC Declaration of Conformity:

Addvalue Communications Pte Ltd, 190 Changi Road, #02-02 MDIS Building, Singapore 419974 declares under our sole responsibility that the Product, brand name as Wideye and model:

SKIPPER™ 150 Fleetbroadband satellite communication system, to which this declaration relates, is in conformity with the following standards and/or other normative documents:

ETSI EN 301 444, ETSI EN 301 489-1 &- 20, IEC 60945 / EN 60945, IEC 60950-1 AND EN 60950-1, ITU-R M.1480

We hereby declare that all essential radio test suite have been carried out and that the above named product is in conformity to all the essential requirements of Directive 1999/5/EC.

The Conformity Assessment procedure referred to Article 10 and detailed in Annex [III] or [IV] of Directive 1999/5/EC has been followed with involvement of the following notified body (ies):

TIMCO ENGINEERING, INC., P.O BOX 370,NEW BERRY, FLORIDA 32669.  
Identification mark: 1177 (Notified Body number)

The technical documentation relevant to the above equipment are held at:

- Addvalue Communications Pte Ltd, 190 Changi Road, #02-02 MDIS Building, Singapore 419974.
- Signed by Mr. Tan Khai Pang (Chief Technology Officer, 17 July, 2009) and
- Mr. Prabakar Kuttaniseeri (Manager-Quality Engineering, 17 July, 2009).



## Safety Summary

For the sake of safety and protection, please read the user guide before you attempt to use the SKIPPER™ 150 FleetBroadband Terminal. In particular, read this safety section carefully. Keep this safety information where you can refer to it if necessary.

The following general safety precautions must be observed during all phases of operation, service and repair of this equipment. Failure to comply with these precautions or with specific warnings elsewhere in this user guide violates safety standards of design, manufacture and intended use of the equipment.

Addvalue Communications Pte Ltd assumes no liability for the customer's failure to comply with these requirements.

### Hazard Symbols

Avoid touching those areas of the terminal that are being marked with this symbol otherwise it may result in injury.



### Antenna Radiation Warning

During transmission the antenna in the system radiates high power levels of radio frequency. This radiation is considered health hazardous to any personnel that come close to the antenna.

It is important to maintain a separation distance from the transmitting antenna to any personnel of at least 1-meter.



### Distance to Other Radiation Equipment

The antenna shall not be installed near any VSAT or radar at the minimum distance and position specified in the later chapter of the user guide. It may cause damage or interference to the antenna.

## Service

User access to the interior of the terminal is not allowed. Only a qualified personnel authorized by its manufacturer may perform service. Failure to comply with this rule will result in the warranty void.

## Grounding and Antenna Cables

The terminal has provided its mechanical stud, which is intended for the grounding wire to be connected to the hull of vessel.

The antenna cable between the terminal and antenna can be extended with specified distance as long as it can meet any type of antenna's characteristic data, which does not exceed its required attenuation.

The antenna cable is shielded and it should not be affected by any magnetic field. It is recommended to avoid the cable being installed in parallel with any AC wiring as it may possibly cause malfunction of the equipment.

## Vessel's Power Supply

The input DC voltage for SKIPPER™ 150 FleetBroadband Terminal is +12V DC, 8A or +24V DC, 4A. It is recommended to use +24V DC power line, provided that it is available on the vessel.

In case of unavailability of +24V DC power line provided by the vessel, an external AC/DC power supply of 115/230V AC with its output of +24V DC can be used. Please note that the requirements of the AC/DC power supply should take care of high surge current of 25A at 24V DC for 1ms.

## Equipment Ventilation

To ensure adequate cooling of the terminal, 5-centimeter of unobstructed space must be maintained around all sides of the unit except the bottom side. The ambient temperature range of the terminal is: -25°C to +55°C.

The equipment shall not be operated in the presence of flammable gases or fumes as well as any explosive atmosphere. Operation of any electrical equipment in such an environment constitutes a definite safety hazard.

## Keep Away from Live Circuits

Operating personnel shall not remove equipment covers. Component replacement and internal adjustment has to be handled by qualified maintenance personnel. Do not attempt to replace components with the power cable connected. Under certain conditions, dangerous voltages may exist even with the power cable removed. To avoid injuries, always disconnect power and discharge circuits before touching them.

## Obtaining Licensing For Inmarsat Terminals

Under rights given under ITU Radio Regulations, local telecommunications administrations establish and enforce national rules and regulations governing types of emissions, power levels, and other parameters that affect the purity of signal, which may be radiated in the various frequency bands of the radio spectrum.

To legally operate Inmarsat equipment, it is necessary to obtain permission from the local telecommunications regulatory authorities of the country you are operating from. Using your equipment in any country without permission causes you to run the risk of confiscation of the equipment by the local authorities. The normal procedure to bring such equipment into another country is to apply for a license before travel. If a license has not been obtained before travel, the equipment may be put in to storage by local authorities until such time license is obtained.

## Copyright

© Copyright 2010 Addvalue Communications Pte Ltd. All rights reserved.

All rights reserved. This publication and its contents are proprietary to Addvalue Communications Pte Ltd. No part of this publication may be reproduced in any form or by any means without the written permission of Addvalue Communications Pte Ltd.

## Warranty

Addvalue Communications Pte Ltd has made every effort to ensure the correctness and completeness of the material in this document. Addvalue Communications Pte Ltd shall not be liable for errors contained herein. The information in this document is subject to change without notice. Addvalue Communications Pte Ltd makes no warranty of any kind with regard to this material, including, but not limited to, the implied warranties of merchantability and fitness for a particular purpose.

## Trademarks

All trademarks, marks, names, or product names referenced in this publication are the property of their respective owners, and Addvalue Communications Pte Ltd neither endorses nor otherwise sponsors any such products or services referred to herein.

Microsoft, Windows, Windows NT, Windows 2000, and Windows XP are registered trademarks of Microsoft Corporation in the U.S.A. and/or other countries.

INMARSAT is a trademark of the International Mobile Satellite Organization. The Inmarsat LOGO and the trademark BGAN are trademarks of Inmarsat (IP) Company Limited. All trademarks are licensed to Inmarsat Limited.

All other company and product names may be the registered trademarks or trademarks of their respective owners.

# Chapter 1

## Introduction

The SKIPPER™ 150 User Equipment (UE) is a dedicated compact solution specifically designed to meet the FleetBroadband services for the maritime environment providing seamless ocean coverage from 76° North to 76° South. FleetBroadband is the marine version of the highly successful BGAN (Broadband Global Area Network) from Inmarsat.

Through a compact antenna, it provides constant, simultaneous access to voice and high-speed data in a compact solution. Allowing you to run online operation systems, and still having access to email, intranet and voice calls - achieving greater operational efficiencies and significantly reducing the cost of both business and crew communications.



Listed is the range of services available for the SKIPPER™ 150 User Equipment:

- Email and webmail
- Secure communications
- Remote intranet and internet access
- SMS and instant messaging
- Videoconferencing
- Phone services
- Store and forward video
- Large file transfer

## Features

The SKIPPER™ 150 UE offers the following features:

- Simultaneous voice and broadband data service over FleetBroadband
- Full duplex, single or multi-user, up to 150 kbps
- Standard Voice (4kbps AMBE+2)
- Send and receive text messages as per Standard 3G (up to 160 characters)
- Built-in Web Console allowing you to manage your phone book, messages and calls, and customize the terminal to your specific needs

## Interfaces

The SKIPPER™ 150 UE has the following connecting interfaces:

- Dedicated Primary Handset port
- GPS output port
- LAN port supporting Power over Ethernet (PoE) for computers, routers and access points.
- Standard RJ11 Phone port for analog (corded or cordless) phone
- Input DC power of +12V DC / +24V DC

## Operating Environment

ADU (Above Deck Unit)	
Operating Temperature	-25 to +55°C
Storage Temperature	-40 to +85°C
BDU (Below Deck Unit)	
Operating Temperature	-25 to +55°C
Storage Temperature	-40 to +80°C
Primary Handset	
Operating Temperature	-20 to +55°C
Storage Temperature	-30 to +70°C
System	
Power Supply	+12V / +24V DC
Power Consumption (max)	100W including antenna
Operating Humidity	95% non-condensing at +40°C

## Mechanical Specifications

ADU (Above Deck Unit)	
Size	294mm (Diameter) x 228mm (Height)
Weight	2.0 kg
BDU (Below Deck Unit)	
Size	297 x 228 x 77mm
Weight	2.8 kg
BDU (Below Deck Unit)	
Size	142 x 56 x 22 mm (without cradle) 147 x 65 x 32 mm (with cradle)
Weight	0.39 kg (without cradle) 0.445 kg (with cradle)

## Main Units

The SKIPPER™ 150 UE includes the following main units:

- SKIPPER™ 150 FleetBroadband ADU (Above Deck Unit) with its 10-meter Antenna Cable
- SKIPPER™ 150 FleetBroadband BDU (Below Deck Unit) which also includes the following:
  - Below Deck Unit
  - Primary Handset
  - Wall-mounted Cradle
  - 1.8-meter DC Power Cable
  - Cable Pack including RJ45 Ethernet Cable and RJ11 Telephone Cord
  - User Guide Manual, Quick Start User Guide and CD

### FB150 FleetBroadband ADU (Above Deck Unit)

The SKIPPER™ 150 ADU is a medium size, maritime FleetBroadband Class 14, 3-axis marine antenna.

The antenna is self-tracking based on patented beam squint technology. The simple and robust electromechanical system, with one motor per free axis, provides full coverage in azimuth and elevation. Tracking is accomplished by measuring signals being continuously broadcast from the satellite.

The antenna unit includes LNA (low noise amplifier), HPA (high power amplifier) and tracking receiver circuitry to ensure communication even in adverse circumstances.



The radome covers the antenna equipments, which is composed of:

- Antenna Unit
- RF and GPS circuit
- Rotary joint
- Antenna pedestal

All signals (and power) pass through a single coaxial antenna cable, which connects the ADU to the BDU.

## SKIPPER™ 150 FleetBroadband BDU (Below Deck Unit)

The BDU has been developed for maximum flexibility and is the controlling unit for the SKIPPER™ 150 FleetBroadband UE. It features a reliable industry standard interfacing field and enables users to have optimal connectivity no matter what the conditions or your position at sea.

The BDU has a built-in Web Console, which can be accessed from a computer connected to the BDU, using an Internet browser. The Web Console provides easy configuration of the BDU, firmware upgrade and daily use. For more information, see Chapter 4, Using the Web Console.

### Front Panel

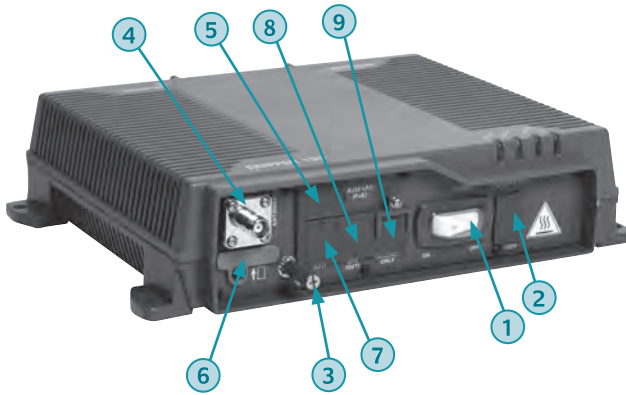

1. Power Switch
2. DC Power Connector
3. Grounding Stud
4. Antenna (Co-Axial) Cable TNC Connector
5. LAN Port (RJ45 with PoE)
6. SIM Card Slot
7. Phone Port (RJ11)
8. GPS Output Port
9. Primary Handset Port



## SIM Card Slot

The BDU has a SIM (Subscriber Identity Module) card slot located at the connector panel behind a small cover plate. The UE requires a dedicated FleetBroadband SIM card to access the FleetBroadband network and configure the settings of the UE.

## Status LEDs

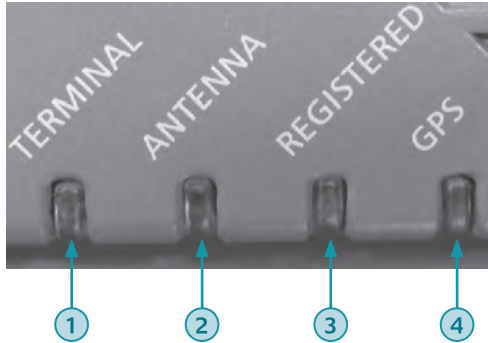

There are 4 Status LEDs to indicate the operational status of the BDU at one glance. Each LED is assigned to the following function:

1. BDU Terminal Status
2. ADU Status
3. Registered to Network Status
4. GPS Status

## Primary Handset

The Primary Handset (corded) has a colour LCD and keypad for making voice calls and sending SMS, which both are similar as any mobile phone. Additionally, it can be used to control and configure the BDU.



The Primary Handset's RJ45 connector is plugged into the BDU's primary handset port and it is powered directly from the BDU. For information on how to use the handset, see Chapter 3, Using the Primary Handset.

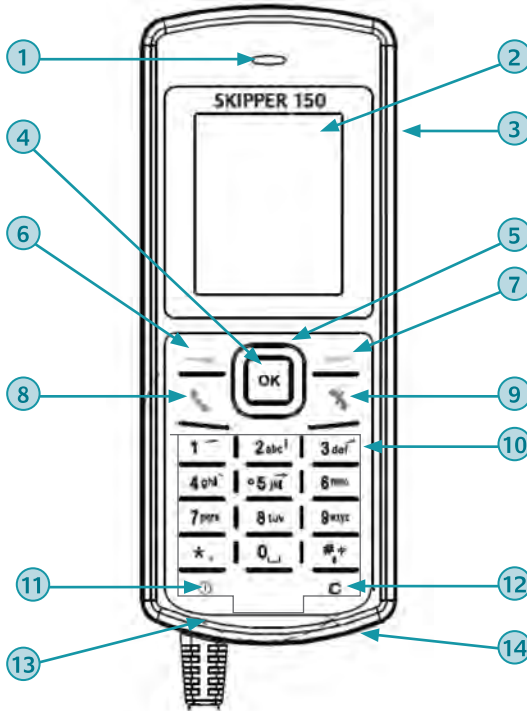

1. Earpiece
2. Display
3. Ear-set Jack
4. OK Key
5. 4-Way Navigation Keys
6. Select Left Key
7. Select Right Key
8. Call/Send key
9. End key
10. Keypad (Alpha-numeric)
11. Power Key
12. Clear Key
13. Microphone
14. Service Port
15. Ringer\*

\*The ringer is located at the back of the Primary Handset.

# Chapter2

## Getting Started

Before proceeding on getting started on the FB150 BDU, the information of how to install FB150 system and the connection of the cables can refer to Chapters 6 and 7 of this user guide.

### Installing the SIM card

The FB150 system requires a dedicated FleetBroadband SIM card to access the FleetBroadband network and configure the settings of the BDU. Please refer to your Airtime Service Provider for more information.

Follow these steps to install the SIM card:

1. Remove the screw that is securing SIM card cover using a T10 Torx screw tool.
2. Remove SIM card cover.

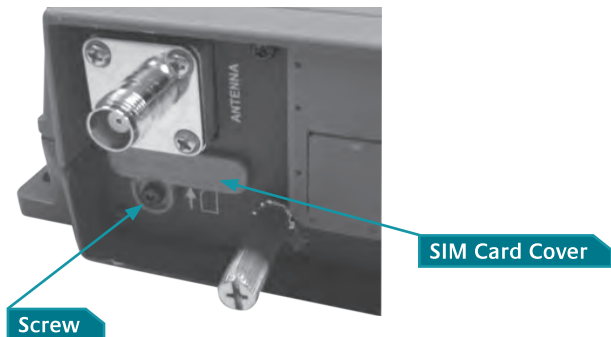

3. Keep SIM card cover and screw in a safe location.
4. With the SIM card's gold-contacts facing up, position the card as indicated and slide it into the slot.



5. Use your finger to push the SIM card gently until it is being clicked and locked in place. Any screwdriver can be helped to push the SIM card if the SIM card cannot be inserted properly.

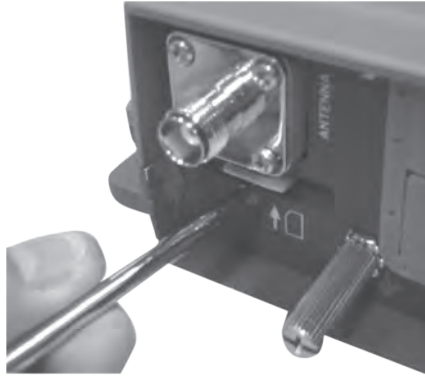

6. Install the SIM cover.
7. Install screw to secure the SIM cover.

## Connecting Antenna (Coaxial) Cable

A 10-meter antenna cable for its connection between the ADU and BDU is provided. It is terminated with TNC (male) and N-Type (male) connectors which are plugged into the BDU and ADU respectively.

Follow these steps to connect the antenna cable to the BDU:

1. Plug antenna cable (terminated with TNC) to the antenna cable connector on the BDU.

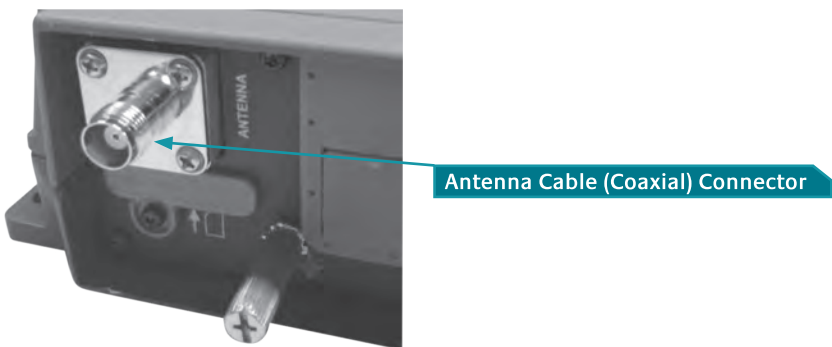

2. Lock the TNC connector till it is being secured to the BDU.
3. For the antenna cable's N-Type, please refer to Chapter 6 of this user guide.

**Note:**

It's important that the antenna cable is connected properly to the FB150 ADU and BDU. Check to ensure that the antenna cable connectors are securely and properly connected.

## Connecting to DC Power Source

Follow these steps to connect the FB150 BDU to the vessel's power source:

1. Connect the power cable plug to the BDU's green DC power socket.



2. Connect the power cable to the vessel's DC power supply. More information of power supply input, please refer to Chapter 7 of this user guide.
3. Turn on the vessel's DC power supply to the FB150 BDU.

## Connecting Primary Handset

**Note:**

The Primary Handset is powered from the BDU through the Primary Handset interface.

Follow these steps to connect the Primary Handset:

1. There is a connection stopper with its screw on the front panel.

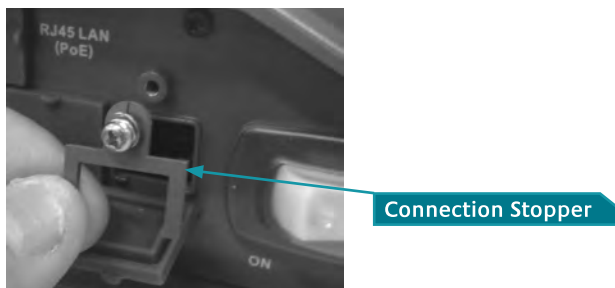

2. Unscrew the connection stopper and then plug in the Primary Handset's connector into the Primary Handset's port on the front panel.
3. Place the connection stopper on the top of the Primary Handset cable's strain relief.

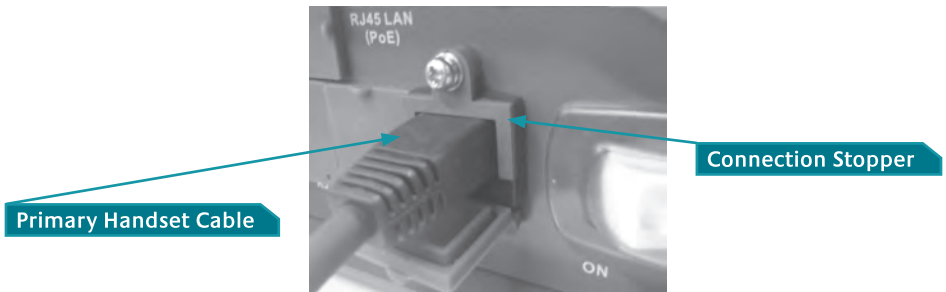

4. Tighten screw on the connection stopper to ensure that the Primary Handset's connector is securely connected to Primary Handset Port on the front panel.

## Powering Up FB150 BDU

Follow these steps to power ON the FB150

1. Tip down the Power Switch on the front panel.





Alternatively, Press and hold the Power  button on the Primary Handset for 4 seconds.

Follow these steps to power OFF the FB150

1. Tip up the Power Switch on the front panel.
2. Press the Power  button on the Primary Handset for 4 seconds. \*

**\*Note:** If there is a message appearing as “Please use the terminal switch to power down”, this means that the Power  button on the primary handset is disable as

default. In order to enable it, press  to select Menu and 4-way navigation ring to select Phone Manager -> Factory settings -> Power button -> Enable and press  to confirm selection.

## Entering your SIM PIN

When you acquire the SIM card from the Airtime Service Provider, a PIN (Personal Identification Number : 4 to 8 digits) is provided together with it.

**Note:**

**You will need to enter the PIN at start-up if the FB150 BDU has been powered down.**

Follow these steps to enter the SIM PIN:

1. Using the keypad on the Primary Handset, enter the SIM PIN.
2. Press  to confirm the SIM PIN.

**Note:**

**If more than three (3) incorrect attempts were used to enter the PIN code, the handset will be locked and will display “xxxxxxx”. You will be required to use the PUK code to unlock the SIM card and to reset your PIN code.**

## Making the first voice call

**Note:**

**To make a call, the FB150 system must be connected to a FleetBoardband network with an adequate signal strength signal of at least 50 dBHz.**

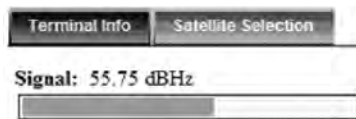

When the ADU Status and Network Status LED indicators on the terminal both light steady green, you are ready to make or receive the first voice call.

To make a call from the Primary Handset, dial **00 <country code> <phone number> followed by the  key.**

**Note:**

**For international calls and SMS, press and hold the \* + key until '+' is displayed, then enter <country code> and <phone number> without using the leading "00".**

To end the call, press  on the Primary Handset.

To accept an incoming call, press  on the Primary Handset.

To make a call from an analog phone (optional) connected to the FB150 BDU's Phone port, off-hook the phone and dial, **00 <country code> <phone number>** followed by the **#** key.

### Sending the first SMS (Message)

Follow these steps to send the first SMS:

1. Using the keypad on the Primary Handset, enter the SIM PIN.
2. Press  to select Menu.



The Menu selection screen will be displayed on the Primary Handset screen.

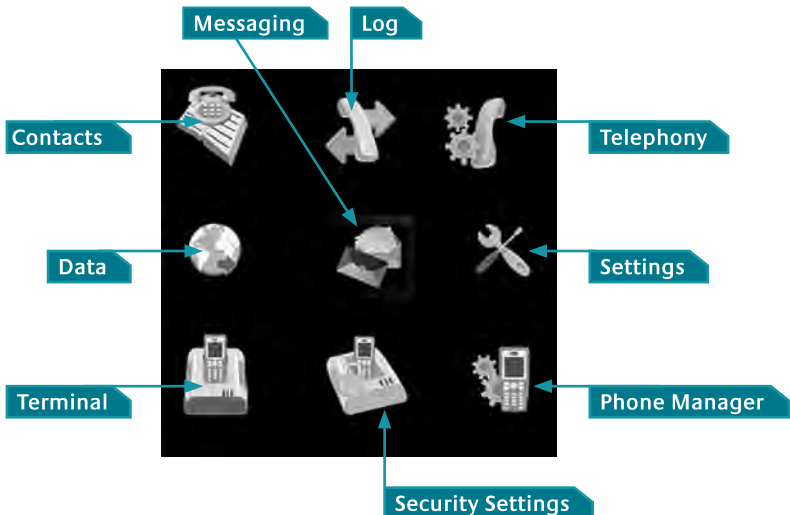

3. Using the 4-way navigation ring, navigate to the Messaging  icon.



4. Press  to confirm selection.  
The SMS editor will be displayed on the Primary Handset screen.
5. Type in your SMS message using the Primary Handset alpha-numeric keypad.

### **Tips for writing text:**

- To add a space, press the **0** key.
- To quickly change the text input method when writing text, press  repeatedly and check the indicator at the top of the display:
  - **<ABC>**: Capital letters
  - **<123>**: Numbers
  - **<abc>**: Small letters
  - **<Abc>**: Initial Capital letter followed by small letters
- To add a number, press and hold the desired number key.

### **Insert symbols to your message:**

- To get a list of special symbols, press **\* +**.
- Using the 4-way navigation ring, navigate to the desired symbol.
- Press  to confirm selection

### **Clearing text:**

- To clear text, press **C** once to clear one character at a time.
- To clear the whole text entry, press and hold **C** to clear the whole text entry.

## **Making the first PDP connection**

### **Note:**

**For the LAN (Local Area Network) interface to work without any further setup, the computer must be set up to obtain an IP address and a DNS server address automatically.**

Follow these steps to connect a computer to the FB150 BDU:

1. Connect your LAN cable between the network connector on your computer and the first LAN port on the FB150 BDU.
2. Power up your computer.
3. Start your Internet browser.
4. Type **http://192.168.1.35/** in the **Address** field and press **Enter**.

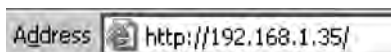

The Login screen appears.

5. Type in **admin** in the **Username** field and **wideye** in the **Password** field. Click **OK**.



Username:

Password:

syncstatus enabled

Login

The FB150 Web Console will open. The Terminal will proceed automatically to “Checking PIN status” followed by “Antenna pointing” and then registering to the network (upon power on).

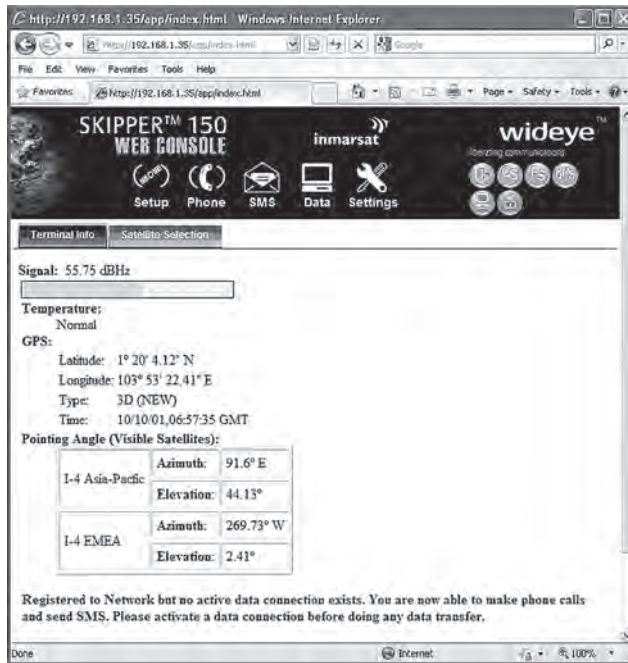

6. Click on . On the Data menu, select **Connection**



7. Click on **Activate Default Profile**. The PDP context will be activated. When connected, APN and IP Address details will be displayed. You may now browse the Internet, do file transfer (FTP) or run any IP based applications services.

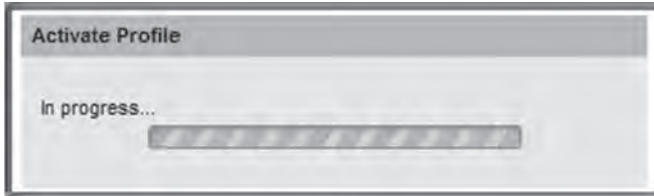

Follow these steps to disconnect the data connection:

1. Click Disconnect (Disconnect (Standard)) to deactivate the PDP context. The PDP context will be deactivated.



# Chapter3

## Using the Primary Handset

### The Primary Handset

The Primary Handset is connected to the BDU using the dedicated HANDSET port and is powered directly from the UE. Equipped with a large 1.5", 65K CSTN, 128 x 128 dots Liquid Crystal Display (LCD), Primary Handset not only acts as a standard phone that allows you to make/receive voice calls, it also serves as a remote access TE (Terminal Equipment) for you to access various configurations supported by the UE.

Primary Handset offers the following features:

- ✓ Making standard CS voice calls
- ✓ Making standard PS background data connections
- ✓ Messaging (SMS)
- ✓ User contacts (combined SIM and UE storage)
- ✓ Speed dial
- ✓ Call logs
- ✓ Managing UE security settings
- ✓ Accessing UE settings that includes:
  - Ethernet
  - Ciphering control
  - Satellite selection
  - Supplementary services
  - Terminal restart
  - Limited factory reset
- ✓ Displaying various UE status and information
- ✓ Local handset configurations



## Powering Up the Primary Handset

The Primary Handset is automatically powered up once it is connected to the dedicated **HANDESET** port. Depending on the conditions of the UE, the Primary Handset may start in the following modes:

### Full functioning mode

Primary Handset starts in this mode once it has successfully connected to the UE and there is no PIN authentication required. All UE settings including contacts, messages and call logs are loaded into local memory of the Primary **Handset** once the UE is configured. You will be able to access all the menus and making voice or data calls once the Primary Handset is ready.



### PIN mode

Primary Handset starts in this mode once it has successfully connected to the UE and PIN authentication is required. Depending on the enabled PIN, you are required to enter the correct PIN/password before proceeding to **Full functioning mode**. Refer to **Security settings** menu for more information on the types of security PIN in the UE.

#### To enter the PIN:

1. Key in the PIN of the security key using the alpha-numeric keypad.
2. Press  key to confirm.

#### To cancel PIN entering:

1. Press the Right  selection key.
2. Confirm to start in Emergency only mode by pressing the  key.

### Emergency only mode

Primary Handset starts in this mode once it has successfully connected to the UE and PIN entering is bypassed (i.e. when you have forgotten the required PIN). You can only make emergency calls or access local **Phone manager** menu in this mode.



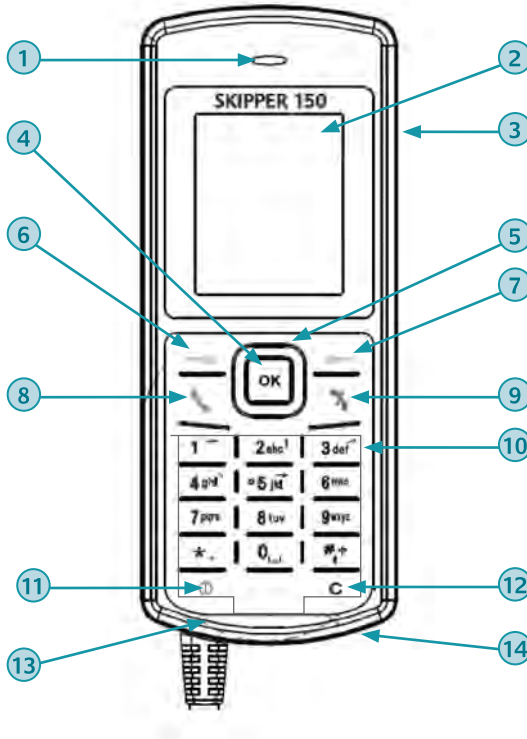



## Primary Handset Keypad



1. Earpiece
2. Display
3. Ear-set Jack
4. **OK** Key
5. 4-way navigation ring
6. Select Key (Left)
7. Select Key (Right)
8. Call/Answer key
9. Call/Menu End key
10. Keypad (Alpha-numeric)
11. Power Key
12. Clear Key
13. Microphone
14. Service Port
15. Ringer\*

\*The ringer is located at the back of the Primary Handset.

## Keypad - Description and Functions



Keys	Description/Functions
	<p><b>4-way navigation ring.</b></p> <p>Press the 4-way navigation ring to scroll left, right, up, and down on the display. Enables scrolling through names, phone numbers, menus or settings.</p>
	<p><b>OK key.</b></p> <p>Pressing this key selects/confirms the function highlighted on the display.</p>
	<p><b>Left selection key.</b></p> <p>The function of this key depends on the guiding text shown on the display above the key.</p>
	<p><b>Right selection key.</b></p> <p>The function of this key depends on the guiding text shown on the display above the key.</p>
	<p><b>Call/Answer key.</b></p> <p><b>After entering a phone number:</b> Initiates a call to the number.</p> <p><b>From Main Display screen:</b> Opens a list of dialed calls.</p> <p><b>When Ringing:</b> Answers the incoming call.</p>
	<p><b>Call/Menu End key.</b></p> <p>Press this key to end active calls or exits from any menus or sub menus.</p>
	<p><b>Keypad.</b></p> <p>Used to enter numbers and characters. Press <b>0</b> to add a space when writing text.</p> <p>The functions available depend on whether you are typing a phone number (number mode) or text (text mode).</p>

Keys	Description/Functions
* +	<p><b>Star * key.</b></p> <p>When entering a phone number, press this key to insert a *. Press and hold this key to insert a +.</p> <p>When writing text, press this key to access a list of special symbols.</p>
# ↕	<p><b>Hash # key.</b></p> <p>When entering a phone number, press this key to insert a #.</p> <p>To quickly change the text input method when writing text, press this key repeatedly and check the indicator at the top of the display.</p> <p>In standby mode, press and hold this key to set the Primary Handset into silent mode.</p>
ⓘ	<p><b>Power key.</b></p> <p>Press and hold this key to power on/off the UE and Primary Handset when the power button is enabled.</p>
C	<p><b>Clear text.</b></p> <p>Press key once to clear one character at a time or press and hold this key to clear the whole text entry.</p>



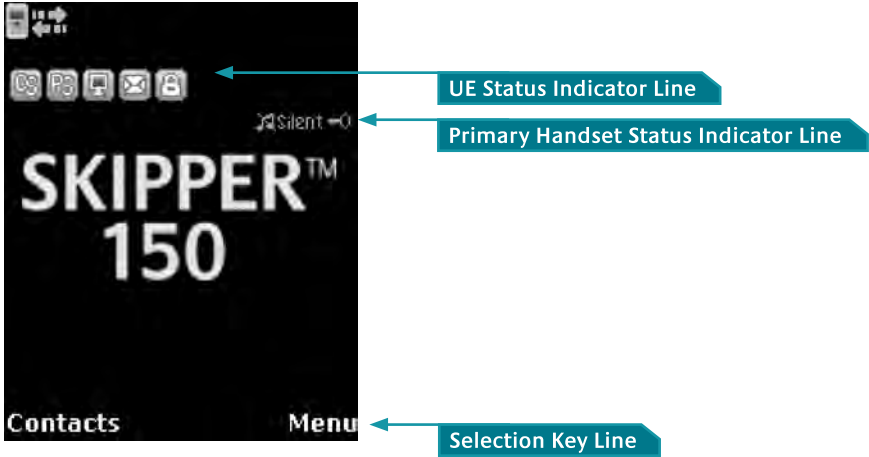









## The Main Display Screen



- **UE Status Indicator line**  
The indicator line shows status symbols informing you about the operating conditions of the UE.
- **Handset Status Indicator line**  
The indicator line shows status symbols informing you about the operating conditions of the Primary Handset.
- **Selection Key line**  
The Selection key line operates using the Left  and Right  selection keys with the  to access menus and controls.

## Primary Handset Status Indicators



Table below explains the meaning of each status indicator displayed in the Main Display screen.

Status Indicator	Description
	New short message (SMS) in inbox
	Available PS domain services
	Available CS domain services
	Data connection is inactive (available in <b>Manage profiles</b> sub menu only)
	Data connection is active
	Ciphering enabled
	Primary Handset keypad lock is active
	Primary Handset disconnected from UE
	Primary Handset connected to UE
	Primary Handset in silent mode

## Making a Voice Call

### Note:

Before making a voice call, please make sure that:



- The Primary Handset is connected to the UE (  status indicator should be on)
- The UE has successfully registered with the network and ready for CS domain (voice) services (  status indicator should be on)

You can use the following two options for making a call:

- **Manual Dial:**

1. Using the alpha-numeric keypad, dial **00 <country code> <phone number>**.
2. Press  key.

- **Using Contacts or Call Log list from the Primary Handset:**

- Enter the **Contacts** list of the Primary Handset, scroll to the desired number and press  key, or
- Enter the **Log** list of the Primary Handset, scroll to the desired number and press  key.

### Note:

For voice calls and SMS, you may also use '+' by pressing and holding the \* + key instead of "00" at the beginning of dialed number string as an alternative ('+' <country code> <phone number>).

## To End a Call

1. Press .

## Receiving a call

When there is an incoming call, the Primary Handset will,

- Ring.
- The calling party's number will be displayed on the screen.

If the number is stored in the contacts, the corresponding name of contact will be displayed.

To answer an incoming call, press the  key.

## Adjusting volume during a call

Use the 4-way navigation ring  to adjust the volume.



## Using the Menus

You can access the Menu System by pressing the Right  selection key in the Main Display screen.

The main menu of the Primary Handset includes nine (9) menu options with each menu option having their respective sub-menus.













You can use the 4-way navigation  ring to navigate to the desired menu option and press  to confirm your selection. You can also end the menu or sub menu and return to the Main Display screen at any time by pressing the  key.

Table below summarizes the functionalities within each menu option:

	<b>Contacts</b> This menu manages your user contacts.
	<b>Log</b> This menu allows you to view call histories.
	<b>Telephony</b> This menu configures settings related to CS voice telephony services.
	<b>Data</b> This menu configures settings or connections related to PS data services.
	<b>Messaging</b> This is menu is for SMS related services.
	<b>Settings</b> This menu configures general UE settings.
	<b>Terminal</b> This menu displays general UE information.
	<b>Security settings</b> This menu configures security settings related to the UE.
	<b>Phone manager</b> This menu configures local handset settings.



## Contacts Menu

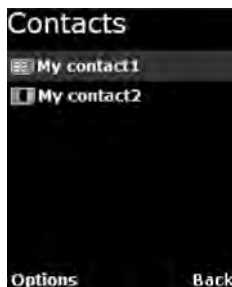

The **Contacts** menu allows you to store, retrieve and update names and phone numbers of your contacts in the Primary Handset memory and in the SIM card memory. You can also access this menu by pressing Left  selection key in Main Display screen.

This menu lists all the contacts saved in both the UE and SIM card memory where,



Indicates contacts that are saved in UE and



Indicates contacts that are save in SIM card.

The following options are available when pressing the Left  selection key while browsing through the contacts:

- **New contact**

Add new contact to the memory. To add contact:

1. Select **New contact**.
2. Select where you want to store the contact (Terminal or SIM).
3. Enter the name for the contact.

**Note: Press \* + key to browse for symbols.**



4. Enter the number for the contact.

**Note: Stored number can be in any one of the following formats:**

- '+' <country code> <phone number>
- 00 <country code> <phone number>

**Press \* + key to insert '+' sign.**

**Saving of contact without number is not allowed.**

5. Select **Save** (Left  selection key) or pressing the  key to save the contact to the selected memory.

**Note:**

**Refer to “Tips for writing the text” section under New message for more information on text writing.**

- **Search**

Select this to enter a specific name to search within the contact list.



- **Delete**

Delete selected contact.

**Note:**

You can also delete the selected contact by pressing the Clear **C** key.

- **Copy**  
Select this to copy the selected contact from SIM card memory to UE memory or vice versa.
- **View number**  
Display the number of the selected contact.
- **Assign Speed Dial**  
Add the selected contact to the speed dial list.
- **Reload Contacts**  
Select this to reload contacts from the UE/SIM card into the local memory of the Primary Handset.
- **Memory Status**  
Select this to view the memory status of the contacts.

While browsing through the contact list, press the  key to view the phone name and number or the selected contact. The following options are available when pressing the Left  selection key while viewing the selected contact:

- **Call**  
Make a voice call to this contact.
- **Send message**  
Open a SMS editor to send a text message to this contact.
- **Edit contact**  
Edit information of this contact.
- **Delete**  
Delete this contact.
- **Copy**  
Select this to copy this contact from SIM card memory to UE memory or vice versa.
- **Forward contact**  
Forward information of this contact using SMS.
- **Assign Speed Dial**  
Add this contact to the speed dial list.

**Note:**

You can also make a voice call to the selected contact when browsing through or viewing the contacts by pressing the Call  key.



## Log Menu

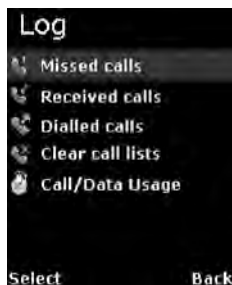

The **Log** menu allows you to view historical information about phone calls and data usage in chronological order with the following sub menus:



### Missed calls



### Received calls



### Dialed calls

Call history of the particular category is displayed in chronological order when selected. Up to 5 latest entries of each category can be saved.

The following options are available when pressing the Left  selection key while browsing through or viewing the call log:

- **Delete**  
Delete the selected log entry from the list.
- **Note:**  
**You can also delete the entry by pressing the Clear  key.**
- **Call**  
Call the number in the selected log entry.
- **Send**  
Send an SMS to the number in the selected log entry.
- **Save**  
Save the number from the selected log entry to the contact list.

**Note:**  
**This option is not available when the log entry already has an entry in the contact list.**

**Note:**  
**You can also make a voice call to the number of the selected log entry when browsing through or viewing the call log by pressing the Call  key.**





## Clear call lists

Select this to clear the call log entries. Available log options are:

- **Missed calls**
- **Received calls**
- **Dialled calls**
- **All calls**

Delete all logs including **Missed**, **Received** and **Dialled** logs.



## Call/Data usage

Display the accumulated call and data duration. Press Left  selection key to clear the call or data duration.





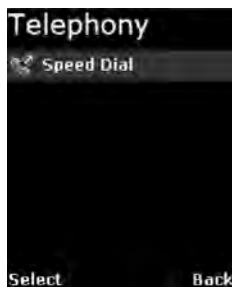

## Telephony Menu



The **Telephony** menu allows you to configure telephony related settings with the following sub menus:

### Speed dial

- **Setting**  
Contain options to enable/disable the speed dial feature.
- **Speed Dial List**  
Select this to configure the speed dial list. The following options are available when pressing the Left  selection key while browsing through the list:
- **Assign**  
Assign a contact to the selected entry. To assign a contact:
  1. Select **Speed Dial** List.
  2. Browse through the list to locate an empty entry.
  3. Select **Options** by pressing Left  selection key.
  4. Select **Assign** and press  from the option.
  5. Select the desired contact to assign to the speed dial list.
  6. Press  to confirm your selection.
- **Delete**  
Remove contact from the selected entry. This option is not available for empty entry.  
  
**Note:**  
**You can also delete the entry by pressing the Clear **C** key.**
- **Call**  
Make call using the number from the selected entry. This option is not available for empty entry.

**Note:**

**You can also make a voice call to the number of the selected entry by pressing the Call  key.**

You can make a voice call directly from the Main Display screen by pressing the corresponding speed dial entry number + Call  key once the speed dial feature is enabled with a valid contact entry.



## Data Menu

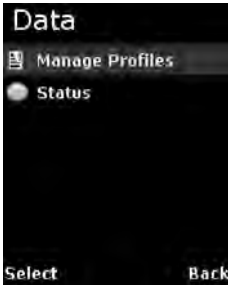

The **Data** menu provides the following sub menus to manage and configure data connections (PDP profiles) for the UE:

### Manage profiles

Allow you to manage the Primary PDP profiles. One **Standard** Primary PDP profile has been created in the profile list as a default profile. You can press the Left  selection key for options available when browsing through the profile list. The list of options is:

- **Edit**  
Edit the selected profile.
- **Delete**  
Delete the selected profile.
- **Add**  
Add new profile into the list.
- **Reset table**  
Reset profile list. All profiles will be deleted and a default profile is created.

### Adding/Editing profiles

You can press the Left  selection or  key from the option list to add new or edit existing profile settings.

- **Profile name**  
Specify the name of the profile.
- **Connection type**  
Only **Standard** connection type is supported.
- **APN**  
Specify information of the APN (Access Point Name). Further available settings are:

**APN:** Specify the Access Point Name for the connection. Default APN is according to SIM card. Enter your own APN if you do not want to use the default APN from the SIM card.

**Username:** Specify the user name for **Static** IP configuration. Default is blank for **Dynamic** IP configuration.



**Password:** Specify the password for **Static** IP configuration. Default is blank for **Dynamic** IP configuration.

You can press the Left  selection key for the following options:

- **Edit**  
Edit the selected APN setting.
- **Fetch from SIM**  
Fetch the APN from the SIM card. This option is only available when APN is highlighted.
  
- **IP configuration**  
Contain options for **Static** or **Dynamic** IP. Default is **Dynamic** IP configuration.
- **IP address**  
Specify the IP address for **Static** IP configuration. This field is ignored for **Dynamic** IP configuration. Default is blank for **Dynamic** IP configuration.
- **Header comp**  
Contain options to enable or disable header compression. Default is **Enabled**.

**Note:**

**You will be prompted to save the changed settings before exiting the sub menu. Press Left  selection key or  key to save the changes.**

Icon  in the profile list indicates that the profile is not active and icon  indicates that the profile is currently active in use.

## **Status**

Allow you to check the status of the data connection. You can also activate/de-active a specific profile in the status display list.







**Note:**

**You will not be able to enter this sub menu if the UE has not been registered for PS data service.**

The status list shows you the current active data connection. Depending on whether there is an active connection, you can press the Left  selection key for the following options:

- **Activate primary**  
This option is available when there is no active data connection. Select this to choose from the profile list for activation.
- **Deactivate**  
This option allows you to de-active an active data connection.





### To active a primary data connection when there is no active connection:

1. From the data status list, select Options using the Left  selection key.
2. Select **Activate primary** using Left  selection key or  key.
3. Select from a list of configured primary profile for activation. Press Left  selection key or  key to confirm.
4. You are prompted to confirm activation. Confirm activation by selecting **Yes** using the Left  selection key or  key.

#### Note:

It may take a while to active a data connection.

### To de-active a primary data connection when there is an active connection:

1. From the data status list, select Options using the Left  selection key.
2. Select **Deactivate** using Left  selection key or  key.
3. You are prompted to confirm de-activation. Confirm de-activation by selecting **Yes** using the Left  selection key or  key.



## Messaging Menu

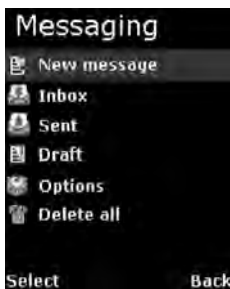

The **Messaging** menu allows the user to write a new messages, view stored messages from **Inbox**, **Drafts** and/or **Sent** folders and configure settings related to SMS with the following sub menus:



## New Message

Select this to create and send a new message. To create new message:

1. Select **New Message** by pressing the **[OK]** key. A SMS editor will be displayed on the Primary Handset screen for writing new message.
2. Type in your SMS message using the alpha-numeric keypad.
3. To send the message, press the **[OK]** key and select **Send**.
4. Enter the recipient's phone number, and press the **[OK]** key. Alternatively you can select **Search** by pressing the Left **◀** selection key to select the phone number from the contacts.

### Options:

You can press the Left **◀** selection key to select options available when writing the message.



- **Send**  
Select this when you are ready to send your message.
- **Save**  
Select this to save the message into the **draft** folder.
- **Clear screen**  
Select this to clear all the written text.

### Tips for writing the text:

- Press the **0** key to add a space.
- To quickly change the text input mode when writing text, press **# ↑ #** key repeatedly and check the indicator at the top of the display:
  - **<ABC >**: Capital letters

- **<123>**: Numbers
  - **<abc>**: Small letters
  - **<Abc>**: Initial Capital letter followed by small letters
- To add a number in alphabet mode, press and hold the desired number key.

### Inserting symbols to your message:

- To get a list of special symbols, press the **\* .** key.
- Using the 4-way navigation ring , navigate to the desired symbol.
- Press  to confirm selection.

### Clearing text:

- To clear text, press **C** once to clear one character at a time.
- To clear the whole text entry, press and hold **C** to clear the whole text entry.



## Inbox

Contain new/opened text messages that you have received. When browsing through the messages list using the 4-way navigation  ring,



Indicates an unread (new) message and



Indicates read (opened) text messages.

The following are available options when pressing the Left  selection key while browsing through or viewing the messages in this folder:

- **Open**  
Open selected message. You can also press  while browsing through the message list to open the selected message (This option is not available when viewing the message).
- **Reply**  
Select this to reply to the selected message sender.
- **Delete**  
Delete selected message.

#### Note:

**You can also delete the selected message by pressing the Clear **C** key.**

- **Forward**  
Forward this message to another recipient.
- **Call**  
Make a voice call to the selected message sender.



- **Save**  
Save the selected message into the Draft folder.
- **Details**  
Display the details of the selected message.
- **Add to contact**  
Select this to add the phone number of the selected message into the contact list.

**Note:**

You can also make a voice call to the selected message contact when browsing through the messages list by pressing the Call  key.



## Sent

Contain text messages that you have sent. The following are available options when pressing the Left  selection key while browsing through or viewing the messages in this folder:

- **Open**  
Open selected message. You can also press  while browsing through the message list to open the selected message (This option is not available when viewing the message).
- **Delete**  
Delete selected message.

**Note:**

You can also delete the selected message by pressing the Clear **C** key.

- **Send**  
Send the selected message to another recipient.
- **Save**  
Save the selected message into the Draft folder.
- **Add to contact**  
Select this to add the phone number of the selected message into the contact list.

**Note:**

You can also make a voice call to the selected message contact when browsing through the message list by pressing the Call  key.



## Draft

Contain text messages that you have saved. The following are available options when pressing the Left  selection key while browsing through or viewing the messages in this folder:

- **Open**  
Open selected message. You can also press  while browsing through the message list to open the selected message (This option is not available when viewing the message).
- **Delete**  
Delete selected message.

**Note:**

You can also delete the selected message by pressing the Clear **C** key.

- **Send**  
Send this message to another recipient.
- **Save**  
Save the selected message into the Draft folder.
- **Add to contact**  
Select this to add the phone number of the selected message into the contact list.

**Note:**

You can also make a voice call to the selected message contact when browsing through the message list by pressing the Call  key.



## Options

The following settings are available in this sub menu:

- **Message Centre**  
Select this to set the number of the SMS service center.
- **Save sent msg**  
Select this to enable or disable the saving of sent messages. When this option is enabled, all successfully sent messages are saved in the **Sent** folder.
- **Memory status**  
Select this to view the memory status of the messages.
- **Reload Messages**  
Select this to reload messages from the UE into the local memory of the Primary Handset.



## Delete all

Select this to clear the messages in a particular folder. Available folder options are:

- **All messages**  
Delete messages in all folders including **Inbox**, **Sent** and **Draft**.
- **Inbox**
- **Sent**
- **Draft**



## Settings Menu

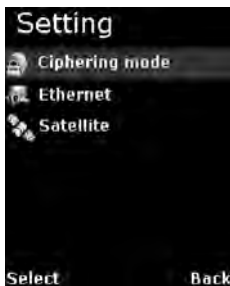

The **Settings** menu provides the following sub menus to configure the UE:



### Ciphering mode

Contain options to enable/disable the use of ciphering mode between the network and UE.

**Note:**



Status icon  is displayed in the Main Display screen when ciphering is enabled.



### Ethernet

Allow you to configure settings related to Ethernet connection.

- **Terminal IP Addr**  
Specify the IP address of the UE. The default IP address of the UE is 192.168.1.35
- **DHCP settings**  
Display the status and settings of the DHCP server.
  - DHCP server**  
Display the status of the DHCP server.
  - Start IP address**  
Display the start IP address of the DHCP server. Default start IP address is 192.168.1.30.
  - End IP address**  
Display the end IP address of the DHCP server. Default end IP address is 192.168.1.49.
  - Primary DNS**  
Display primary DNS server address. Default primary server is 172.30.66.7.
  - Secondary DNS**  
Display secondary DNS server address. Default secondary server is 172.30.34.7.
  - Lease time**  
Display the lease time. Default lease time is 60.

Except for **DHCP** server, the rest of the display settings can be edited by pressing the Left  selection or  keys.

**Note:**

**Make sure that the format is correct when entering an IP address. Press the Star \* + key multiple times to insert the “.”(dot) sign.**



## Satellite

Manage settings related to Inmarsat satellites.

- **Satellite selection**

Allow you to select the preferred satellite to lock on to. Default is AUTO where the UE automatically searches for the best satellite in view to lock on to.

**Note:**

**Satellites visible to the UE are marked with \*. The UE will de-register from the network with all the CS (voice) and PS (data) services terminated whenever a new satellite is manually selected from the list. The UE can only re-register with the network once it has successfully locked onto the newly selected satellite.**

### Satellite status

Display current satellite status. The following information is displayed:

- **Status**

Display status of the UE. The UE can be either searching or locked on to a particular satellite.

- **Satellite ID**

Satellite ID that the UE is currently searching for or locked on.

- **Satellite Name**

Satellite Name that the UE is currently searching for or locked on.



## Supplementary

Configure settings related to supplementary services. These settings are applicable to standard CS voice services.

**Note:**

**Depending on the network, some settings may not be available or may prevent other settings from being activated.**

The following sub menus are available:

- **Call forwarding**  
Allow you to configure for call forwarding services depending on various conditions. The following forwarding conditions are available for configurations:
  - ❑ **All Calls**  
All calls are unconditionally forwarded.
  - ❑ **Busy**  
Calls are forwarded when the UE is busy.
  - ❑ **No answer**  
Calls are forwarded when no answer from the UE for a specific time.
  - ❑ **Not reachable**  
Calls are forwarded when UE is not reachable.

You can press the Left  selection key for options available when browsing through the list of forwarding conditions. The list of options is:

- **Retrieve all**  
Retrieve network settings of all the listed conditions.
- **Update all**  
Update configured settings of all the listed conditions to the network.
- **Cancel all**  
Deactivate all condition settings.

**Note:**

**Operations on this level affect all forwarding conditions and hence it may take some time to process.**

Pressing the  key configures a particular forwarding condition. The following settings can be configured:

**Status:** Display active or Inactive status of the selected forwarding condition. Press the  key to change the status.

**Number:** Display number to forward calls to when selected forwarding condition is active. Press the  key to change the number.

**Time:** Only applicable to **No answer** forwarding condition. To forward calls to selected number if call no answer for a specific period of time. Press the  key to change the time.

You can press the Left  selection key for options available when configuring a particular forwarding condition. The list of options is:

- **Retrieve**  
Retrieve network settings of the selected condition.
- **Update**  
Update configured settings to the network for the selected condition.

**Note:**

**Always use Retrieve all or Retrieve options to retrieve the latest settings from the network. Use Update all or Update options to update the network settings after configurations.**

- **Call barring**

Allow you to configure for call barring services depending on various barring conditions. The following conditions are available for activations/deactivations by pressing the  key:

- **Outgoing calls**

Barring of all outgoing calls.

- **Incoming calls**

Barring of all incoming calls.

- **Int. except home**

Barring of all outgoing international calls except to home country.

- **Incoming if abroad**

Barring of all incoming when roaming.

You can press the Left  selection key for options available when browsing through the list of barring conditions. The list of options is:

- **Retrieve**

Retrieve network settings of the highlighted condition.

- **Retrieve all**

Retrieve network settings of all the listed conditions.

- **Update**

Update configured settings to the network for the highlighted condition.

- **Update all**

Update configured settings of all the listed conditions to the network.

- **Cancel all**

Deactivate all condition settings.

You will be asked to enter the call barring password when updating the settings to the network. Consult your equipment distributor if necessary.

**Note:**

**Always use Retrieve all or Retrieve options to retrieve the latest settings from the network. Use Update all or Update options to update the network settings after configurations.**

- **Call waiting**

Contain options to enable/disable call waiting services. You can also press the Left  selection key for the following options:

- **Retrieve**

Retrieve network settings of the call waiting service.

- **Update**  
Update configured settings to the network.

**Note:**

**Always use Retrieve option to retrieve the latest settings from the network. Use Update option to update the network settings after configurations.**

- **Caller ID**  
Allow you to configure settings that are related to caller identifications.
- **Setting**  
Contain options to configure for USA or Europe caller ID type.
- **Send Caller ID**  
Allow you to enable/disable sending of your caller ID to the recipient when making a call. Default is AUTO where the default network settings are used. You can also press the Left  selection key for the following options:
  - **Retrieve**  
Retrieve network settings of the call waiting service.
  - **Update**  
Update configured settings to the network.

**Note:**

**Always use Retrieve option to retrieve the latest settings from the network. Use Update option to update the network settings after configurations.**





## Terminal Menu

The **Terminal** menu provides the following sub menus to check for information and perform resets on the UE:



### Signal strength

Show graphical representation of current signal strength and GPS type. Table below describes the available GPS type icons used in this sub menu:

	This icon shows that the UE is in the process of acquiring a GPS fix when there is no previously stored GPS fix.
	This icon shows that the UE is using New GPS coordinates.
	This icon shows that the UE is using previously stored GPS coordinates.

### GPS status

Show current Latitude and Longitude coordinates, the GPS type and Time of acquisition on the UE.

### Terminal Info

Display a list of information of the UE.

- **Manufacturer**  
Manufacturer name of the UE
- **Software version**  
Software version of the UE
- **Model**  
Model name of the UE
- **IMEI number**  
IMEI number of the UE
- **IMSI number**  
IMSI number of the SIM card



- **Subscriber number**  
Subscriber's telephone number
- **Serial number**  
Serial number of the UE



### **ADU Info**

Display a list of information of the Antenna.

- **Serial number**  
Serial number of the Antenna



### **Terminal restart**

Soft restarting the UE.



### **Limited reset**

Perform limited reset on the UE. Apart from full factory reset that is not available in Primary Handset, limited reset only resets a small portion of the UE settings. Stored GPS status, contacts, call logs and event logs are not cleared during limited reset.

You are also required to key in the password when performing the reset. The default password is 0000.

**Note:**

**This password is the same as Terminal PIN.**



## Security settings Menu

The **Security Settings** menu provides the following sub menus to configure the security settings of the UE using different PIN:

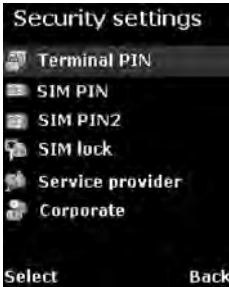

**Terminal PIN**



**SIM PIN**



**SIM PIN2**



**SIM lock**



**Service provider**



**Corporate**

There are three options available for selection under each sub menus to manage the PIN and security settings for the UE:

- **Enable**

Enable the selected PIN. Table below summarizes the default PIN codes for each security setting:

<b>Terminal PIN</b>	0000  <b>Note:</b> <b>Terminal PIN is the same PIN that has to be entered when performing Limited Reset on the UE.</b>
<b>SIM PIN</b>	Depends on your SIM card. Consult your equipment distributor if necessary.  <b>Note:</b> <b>You have to enter the PUK (PIN Unlocking Key) to access the SIM card if a wrong PIN for SIM PIN and SIM PIN2 has been entered for three times. You will be asked to enter the new PIN code once you have entered the correct PUK. However, the SIM card is no longer usable if you have entered wrong PUK for 10 times.</b>

<b>SIM PIN2</b>	Depends on your SIM card. Consult your equipment distributor if necessary.
<b>SIM lock</b>	000000
<b>Service provider</b>	Depends on your SIM card. Consult your equipment distributor if necessary.
<b>Corporate</b>	Depends on your SIM card. Consult your equipment distributor if necessary.

You will be asked to key in the existing PIN (or default PIN if it has not been changed) before the PIN can be enabled.

- **Disable**  
Disable the selected PIN. You will be asked to key in the existing PIN (or default PIN if it has not been changed) before the PIN can be disabled.
- **Change**  
Change the PIN to a new one. You will be asked to key in the existing PIN (or default PIN if it has not been changed) before the PIN can be changed.

**Note:**

**PIN has to be enabled before it can be changed.**



## Phone manager Menu



The **Phone manager** menu provides the following sub menus to configure settings that are local to the Primary Handset:

### Display

Configure settings that are related to Primary Handset display.

- **Backlight**

Used to set the duration of the display backlight to remain on. Settings range from Always On (Backlight permanently on), 15 seconds to 1 minute.

**Note:**

**The backlight will be slightly dimmer and finally off when there is no keypad activity after sometime. However, this feature is not available when the setting is set to Always On).**

### Tone

Configure tone setting for the standard and ring tones.

- **Standard tone**

- **Keytone**

Contain options to enable/disable the key tone.

- **Message tone**

Contain options to enable/disable the message tone.

- **Volume**

Configure the volume for the standard tones (both key and message tones).

Using the 4-way navigation ring , press up/right to increase and down/left to decrease the volume.

- **Ring tone**

- **Tone**

Select desired ring tone pattern.

- **Volume**

Configure the volume of the ring tone. Using the 4-way navigation ring , press up/right to increase and down/left to decrease the volume.



## Language

Allow you to change the menu display language.



## Factory settings

Allow you to configure default factory settings of the Primary Handset. Contains the following settings:

- **Power button**

Provide options to enable/disable the power button. You can press the Power  key to power on/off the UE and Primary Handset once the power button is enabled.

- **Factory reset**

Perform factory reset on the Primary Handset.



## About

Display a list of information of the Primary Handset.

- **Model**

Model name of the Primary Handset.

- **Software version**

Software version of the Primary Handset.

- **Hardware version**

Hardware version of the Primary Handset.

- **Technical support**

Web address for technical support.

- **Copyright**

Contain Copyright message.

# Chapter 4

## Using the Web Console

1. Connect your computer to the FB150 UE using a LAN cable.
2. When the connection has been established, open the web browser.
3. **Type `http://192.168.1.35` in the **Address** field and press **Enter**.**



The Login screen appears.

4. Type in **admin** in the Username field and **wideye** in the password field. Click **OK**.



5. **The FB150 UE Web Console** will appear on your screen.



The FB150 UE will automatically register to the Inmarsat FleetBroadband network. This process will include GPS acquisition, satellite tracking and registration with the network, which will take a few minutes. Once the process is completed, you will see the **“Registered to Network but no active data connection exists. You are now able to make phone calls and send SMS. Please activate a data connection before doing any data transfer.”** message appearing at the bottom line of the Web Console.



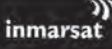

http://192.168.1.35/app/index.html - Windows Internet Explorer

http://192.168.1.35/app/index.html





File Edit View Favorites Tools Help

http://192.168.1.35/app/index.html

Setup Phone SMS Data Settings

Terminal Info Satellite Selection

Signal: 55.75 dBHz

Temperature:  
Normal

GPS:  
Latitude: 1° 20' 4.12" N  
Longitude: 103° 53' 22.41" E  
Type: 3D (NEW)  
Time: 10/10/01,06:57:35 GMT

Pointing Angle (Visible Satellites):

I-4 Asia-Pacific	Azimuth:	91.6° E
	Elevation:	44.13°
I-4 EMEA	Azimuth:	269.73° W
	Elevation:	2.41°

Registered to Network but no active data connection exists. You are now able to make phone calls and send SMS. Please activate a data connection before doing any data transfer.

Done Internet 100%

## Menu Overview



Setup	Phone	SMS	Data	Settings
Terminal Info	Phonebook	Compose	Connection	Language
Satellite Selection	Call History	Inbox	Primary Profiles	Terminal Info
		Sent	Secondary Profiles	Ethernet
		Draft	Port Forwarding	Telephony
			Settings	PIN
				SMS
				Admin
				Support

## Status Indicators



**Note:**

Clicking on these icons gives you a shortcut to the desired menu.

- **Orange** indicates the item is activated.
- **Grey** indicates the item is not activated.

These icons indicate the status of FB150 UE.

### • Status icons



Logout icon: user can log out from the web console.



CS icon: indicates the Circuit Switch status (Voice calls, SMS, FAX).



PS icon: indicates the Packet Switch information (Internet Browsing, FTP, email).



GPS icon: indicates if the current GPS co-ordinates are valid or not.

### • Action icons



Internet icon: Click on this icon to activate or deactivate Internet connection.



Cipherring icon: Click on this icon to enable or disable cipherring.





## Setup Menu

### Viewing Terminal Information

1. Click  .

2. Click **Terminal Info** to view the FB150 UE terminal information.

The terminal information is displayed according to the Satellite Tracking mode.

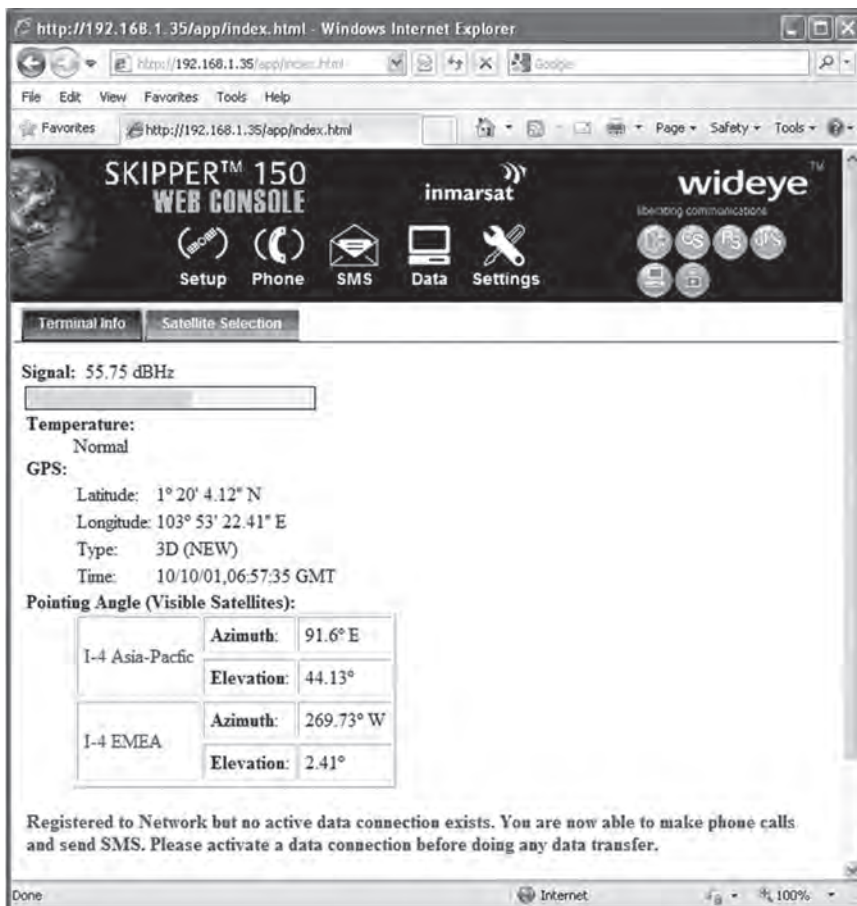

The screenshot shows the 'SKIPPER™ 150 WEB CONSOLE' interface in a Windows Internet Explorer browser. The page title is 'http://192.168.1.35/app/index.html'. The interface includes a navigation bar with icons for Setup, Phone, SMS, Data, and Settings. Below the navigation bar, there are tabs for 'Terminal Info' and 'Satellite Selection'. The 'Terminal Info' tab is active, displaying the following information:

**Signal:** 55.75 dBHz

**Temperature:** Normal

**GPS:**

- Latitude: 1° 20' 4.12" N
- Longitude: 103° 53' 22.41" E
- Type: 3D (NEW)
- Time: 10/10/01,06:57:35 GMT

**Pointing Angle (Visible Satellites):**

I-4 Asia-Pacific	<b>Azimuth:</b>	91.6° E
	<b>Elevation:</b>	44.13°
I-4 EMEA	<b>Azimuth:</b>	269.73° W
	<b>Elevation:</b>	2.41°

Registered to Network but no active data connection exists. You are now able to make phone calls and send SMS. Please activate a data connection before doing any data transfer.

<b>Signal</b>	Indicates the received signal strength.
<b>Temperature</b>	Indicates the UE's BDU current operating temperature status.
<b>GPS</b>	Indicates the latitude, longitude, type and time of the GPS acquisition.
<b>Pointing Angle</b>	Indicates the azimuth and elevation angle of the ADU antenna with the corresponding satellite in view.

## Satellite Selection

The default Satellite Selection is in **Auto** mode. In **Auto** mode, the UE will scan all the visible satellites and track the satellite with the most optimum elevation angle or the last used satellite.

### Note:

**Changing the satellite selection will terminate any existing active voice/fax call or data connections.**

Follow these steps to change your satellite selection:

1. Click  .
2. Click **Satellite Selection** to view the visible satellites.  
The visible satellites will be displayed for your selection.  
It also displays the satellite information that your ADU antenna is locked on to.

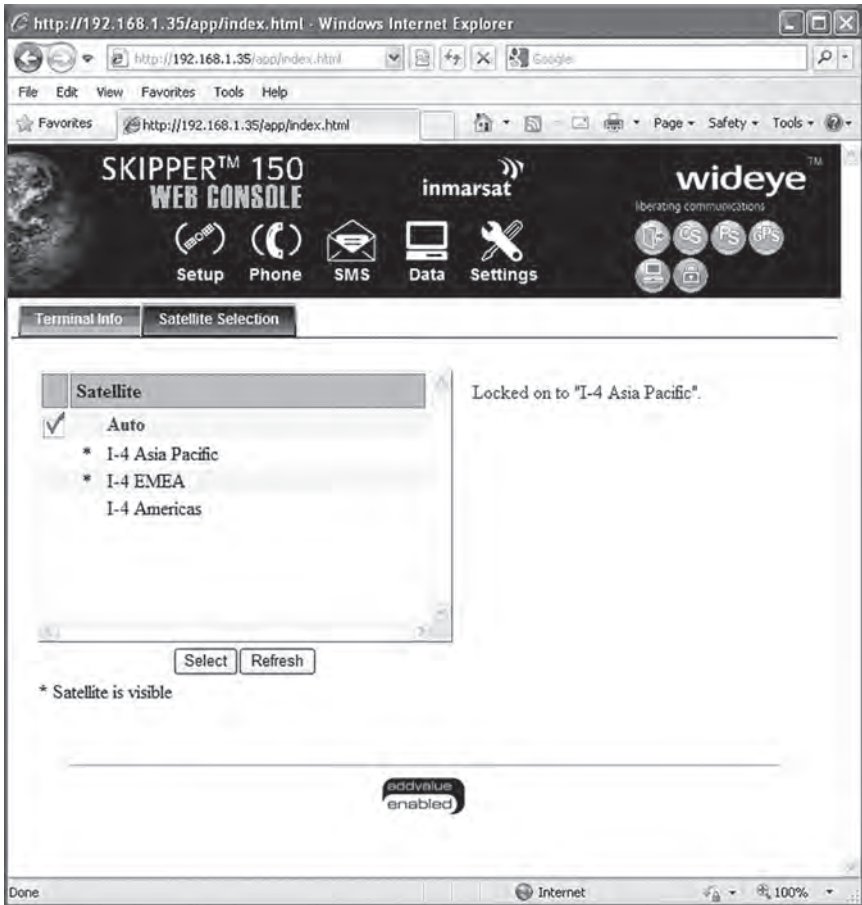

3. Click on your choice of visible satellites.
4. Click **Select** to point the antenna to the selected satellite in exclusive mode. The satellite selection will be saved and each time you power up the UE, the satellite selection choice will remain until you make the next selection change. The UE will track the newly selected satellite even if the elevation angle is not optimum.
  - Click **Refresh** to refresh the Satellite list.



## Phone Menu

Phone menu provide the following options:

- **Phonebook**  
Allows you to view, add, edit and delete entries on your Phonebook list. You can make and send SMS messages directly from your Phonebook entries. The Phonebook entries can be stored on the SIM card or the FB150 UE.
- **Call History**  
To check on the history log of calls made and received.

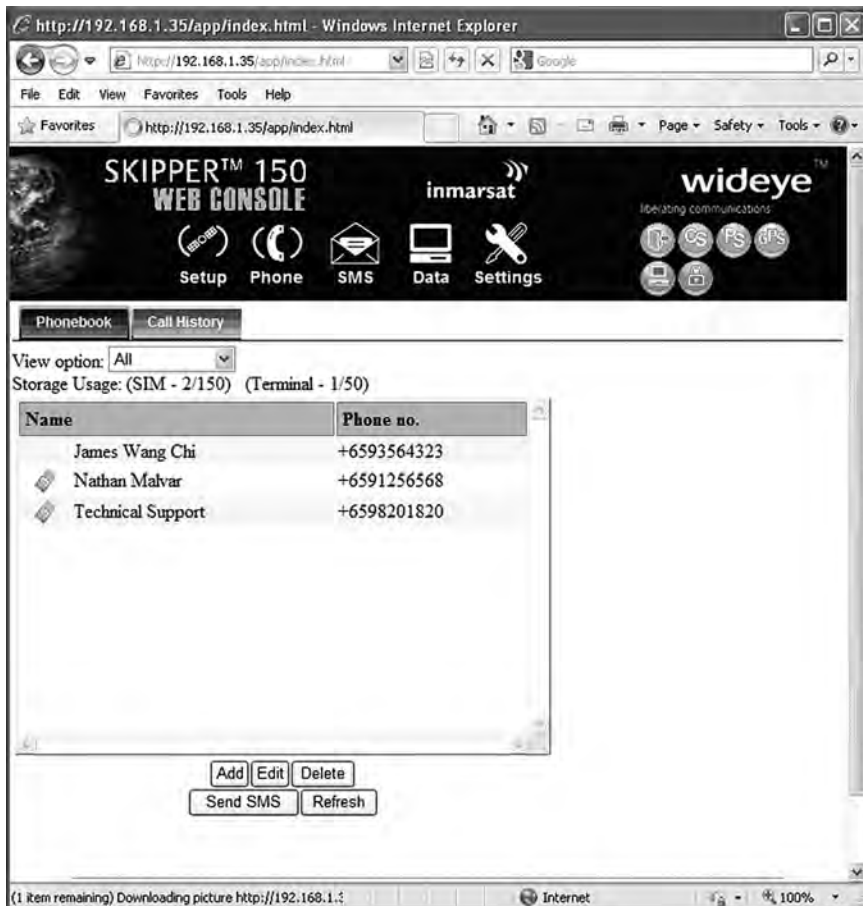

# Phonebook



- View option**

The View option allows you to view the Phonebook entries from the different storage locations.

From the drop-down menu, select:

<b>All</b>	To view the entries stored in the SIM card and FB150 UE.
<b>SIM only</b>	To view the entries stored in the SIM card.
<b>Terminal only</b>	To view the entries stored in the FB150 UE.

- **Storage Usage**

Shows the number for Phonebook entries used in the SIM card and UE locations.

For example: (**SIM – 3/150**) indicates:

Storage location – **SIM** card

Total number of entries used = **3**

Total number of entries available = **150**

## Adding a new Phonebook entry

Follow these steps to add a new Phonebook entry:

1. Click **Add**.
2. Enter the Name and Phone number.
3. Select the storage location and click **Save**.

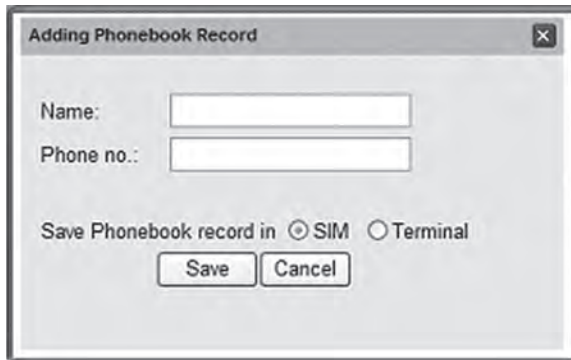

The screenshot shows a dialog box titled "Adding Phonebook Record" with a close button (X) in the top right corner. It contains two text input fields: "Name:" and "Phone no.:". Below these fields, there is a label "Save Phonebook record in" followed by two radio buttons: "SIM" (which is selected) and "Terminal". At the bottom of the dialog, there are two buttons: "Save" and "Cancel".

## Editing a Phonebook entry

Follow these steps to edit a Phonebook entry:

1. Select the entry from the Phonebook list.
2. Click **Edit**.
3. Proceed to change the Name and/or Phone number.
4. Click **Apply**.

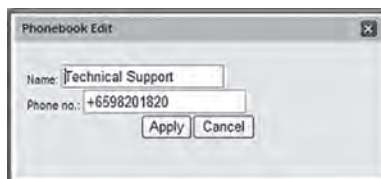

The screenshot shows a dialog box titled "Phonebook Edit" with a close button (X) in the top right corner. It contains two text input fields: "Name:" with the text "Technical Support" and "Phone no.:" with the text "+6598201820". Below these fields, there are two buttons: "Apply" and "Cancel".

## Deleting a Phonebook entry

Follow these steps to delete a Phonebook entry:

1. Select the entry from the Phonebook list.
2. Click **Delete**.
3. Click **Ok** to confirm to delete the entry. Click **Cancel** to abort delete.

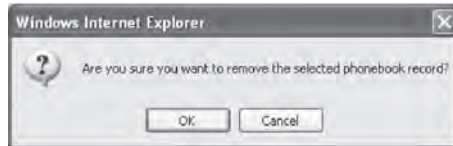

## Sending SMS from the Phonebook

Follow these steps to send SMS from the Phonebook:

1. Select the entry from the Phonebook list.
2. Click **Send SMS**.  
The Phonebook console switches over to the Compose SMS console.

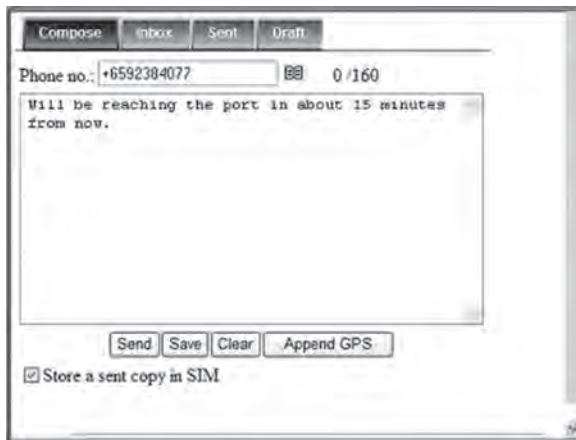

3. Type in the text message and click **Send**.
  - Click **Refresh** to refresh the Phonebook list.

## Call History

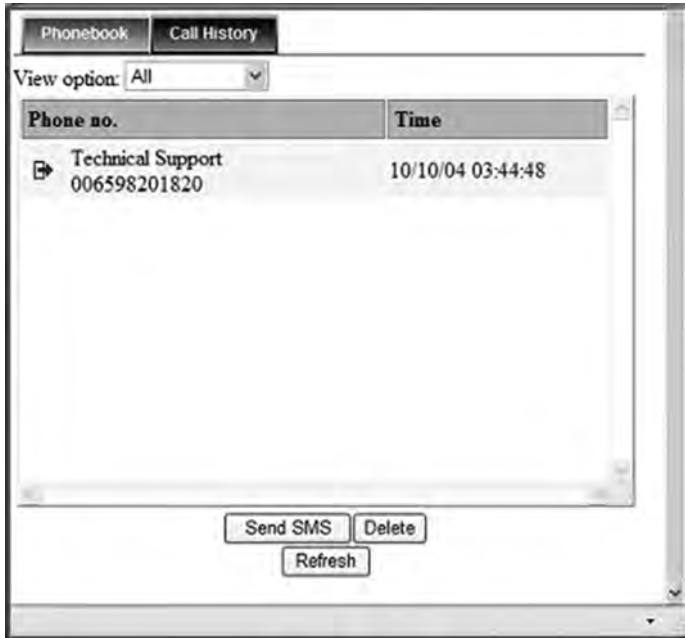

- **View option**

The View option allows you to view the Call History entries.

From the drop-down menu, select:

<b>All</b>	To view the list of the dialed, received and missed calls.
<b>Dialed Call</b>	To view the list of dialed calls only.
<b>Received Call</b>	To view the list of received calls only.
<b>Missed Call</b>	To view the list of missed calls only.

### **Sending SMS from the Call History list**

Follow these steps to send SMS from the Call History list:

1. Select the entry from the list.
2. Click **Send SMS**.  
The Call History console switches over to the Compose SMS console.



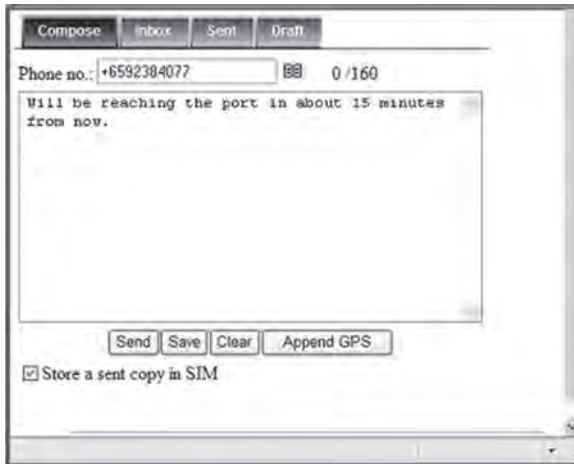

3. Type in the text message and click **Send**.

### Deleting a Call History entry

Follow these steps to delete a Call History entry:

1. Select the entry from the Call History list.
2. Click **Delete**.
3. Click **Ok** to confirm or click Cancel to abort deleting the entry.
  - Click **Refresh** to refresh the Call History list.



## SMS Menu

SMS menu provide the following options:

- **Compose**  
To compose and send text messages. Simply enter a mobile number, type your message and click Send.
- **Inbox**  
Shows the details (Sender information, Message, Date and Time stamp) of all SMS received.
- **Sent**  
Shows the details (Receiver information, Message, Date and Time stamp) of all SMS sent.
- **Draft**  
Stores unsent messages for retrieval later.

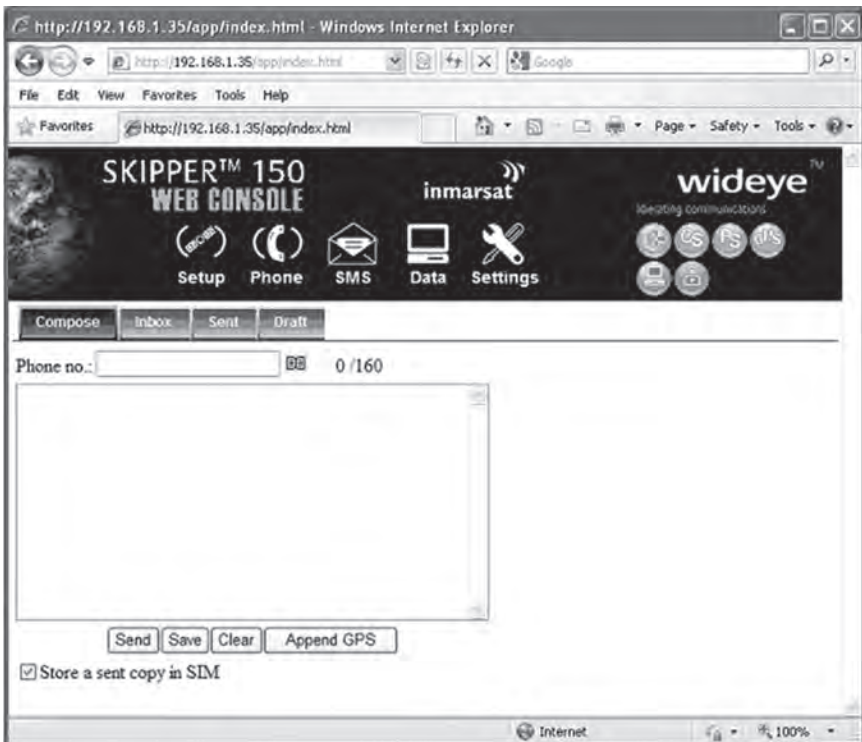

## Composing A New Message

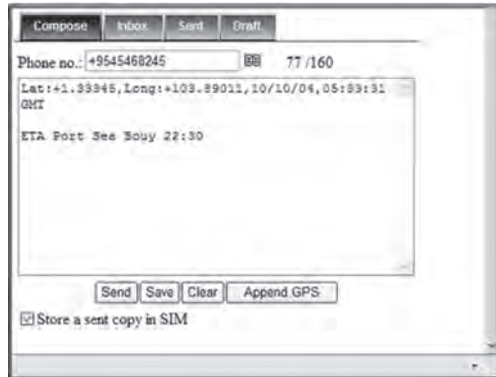

Follow these steps to compose a new SMS:

1. Enter the receiver's phone number in the Phone no. field or click the Phonebook icon  if the receiver's number is listed in the Phonebook.
2. Type the message in the text editor box.

### Note:

**Message is limited to 160 characters including spacing between words. For sending SMS to another BGAN terminal, the message is limited to 608 characters including spacing between words.**

3. Uncheck **Store a copy in SIM** checkbox if you do not wish to store a copy of the sent SMS into SIM card.
4. Click **Send** to send the SMS.
  - To save an unsent SMS, click **Save** and the unsent SMS will be saved in **Draft**.
  - To clear the typed message on the text editor, click **Clear**.
5. Click **Append GPS** to attach the current GPS position to an SMS message prior to sending.

## Inbox

Shows the details (Sender information, Message, Date and Time stamp) of all SMS received.

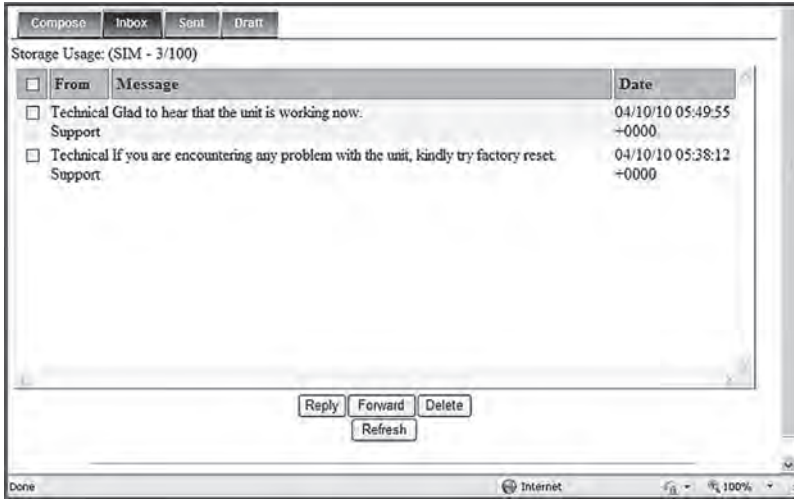

## Replying to a SMS

Follow these steps to reply a SMS:

1. Click on a SMS to select it.  
The selected SMS will be highlighted in light blue.
2. Click **Reply**.
3. Click **OK** to reply with the original contents or **Cancel** to reply without the original content.

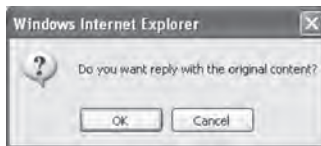

The Inbox console switches over to the Compose console.

4. Enter your reply in the text editor.
5. Click **Send** to send your reply SMS.  
The reply SMS will be sent to the recipient.

## Forwarding an SMS

Follow these steps to forward an SMS:

1. Click on a SMS to select it.  
The selected SMS will be highlighted in light blue.
2. Click **Forward**.  
The Inbox console switches over to the Compose console.
3. Enter the receiver's number in the **Phone No.** field.
4. Click **Send** to forward the SMS.  
The SMS will be sent to the recipient.

## Deleting a single SMS from the Inbox list

Follow these steps to delete a single SMS from the Inbox list:

1. Click on a SMS to select it.
2. Click **Delete**.
3. Click **OK** to confirm or click **Cancel** to abort deleting the SMS.

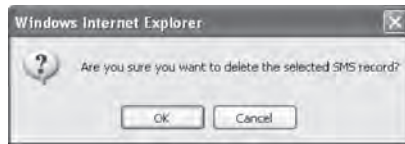

## Deleting multiple SMS from the Inbox list

Follow these steps to delete multiple SMS from the Inbox list:

1. Select the message by checking the checkboxes beside each SMS.
2. Click **Delete**.
3. Click **OK** to confirm the delete, or **Cancel** to abort the delete.
  - Click **Refresh** to refresh the Inbox list.

## Sent

Shows the details (Receiver information, Message, Date and Time stamp) of all SMS sent.

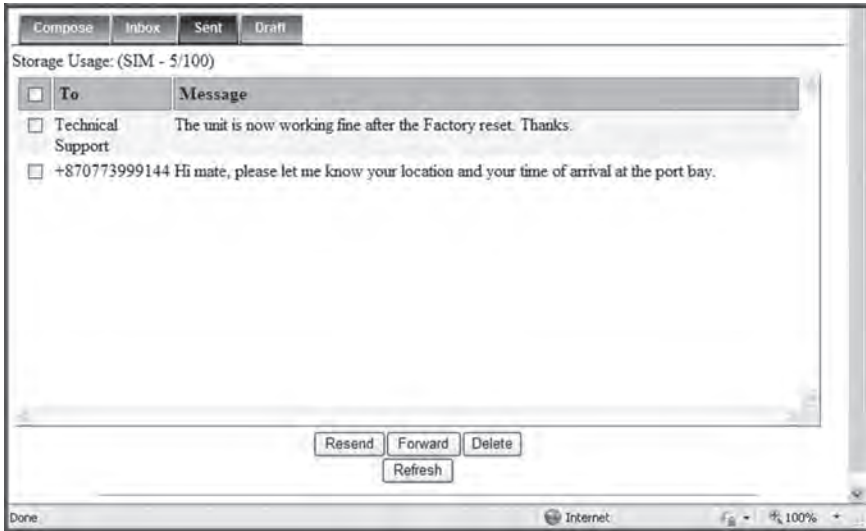

## Resending a sent SMS

Follow these steps to resend a sent SMS (sending the same SMS to the same receiver):

1. Click on a SMS to select it.
2. Click **Resend**.  
The SMS will be sent to the recipient.

## Forwarding a sent SMS

Follow these steps to forward a sent SMS to another recipient:

1. Click on a SMS to select it.
2. Click **Forward**.  
The Sent console switches over to the Compose console.



3. Enter the receiver's number in the **Phone No.** field.
4. Click **Send**.  
The SMS will be sent to the recipient.

## Deleting a SMS from the Sent list

Follow these steps to delete a single SMS from the Sent list:

1. Click on a SMS to select it.
2. Click **Delete**.
3. Click **OK** to confirm or click **Cancel** to abort deleting the SMS.

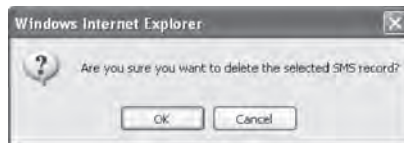

## Deleting multiple SMS from the Sent list

Follow these steps to delete multiple SMS from the from the Sent list:

1. Select the message by checking the checkboxes beside each SMS.
2. Click **Delete**.
3. Click **OK** to confirm the delete, or **Cancel** to abort the delete.
  - Click **Refresh** to refresh the Sent list.

## Draft

Stores SMS saved from the Compose console.



Follow these steps to send a draft SMS:

1. Click on a SMS to select it.
2. Click **Send**.  
The SMS will be sent to the recipient.



## Forwarding a draft SMS to another recipient

Follow these steps to forward a draft SMS to another recipient:

1. Click on a SMS to select it.
2. Click **Forward**.  
The Draft console switches over to the Compose console.



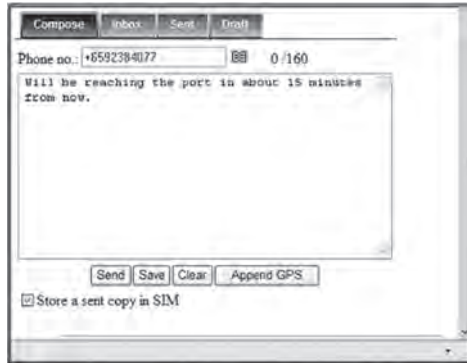

3. Enter the receiver's number in the **Phone No.** field.
4. Click **Send** to forward the SMS.  
The SMS will be forwarded to the recipient.

## Deleting a SMS from the Draft list

Follow these steps to delete a SMS from the Draft list:

1. Click on a SMS to select it.
2. Click **Delete**.
3. Click **OK** to confirm or click Cancel to abort deleting the SMS.

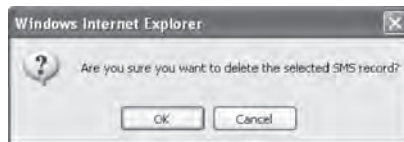

## Deleting multiple SMS from the Draft list

Follow these steps to delete multiple SMS from the Draft list:

1. Select the message by checking the checkboxes beside each SMS.
2. Click **Delete**.
3. Click **OK** to confirm the delete, or **Cancel** to abort the delete.
  - Click **Refresh** to refresh the Draft list.



## Data Menu

Data menu provides the following options:

- Connection
- Primary Profiles
- Port Forwarding
- Settings

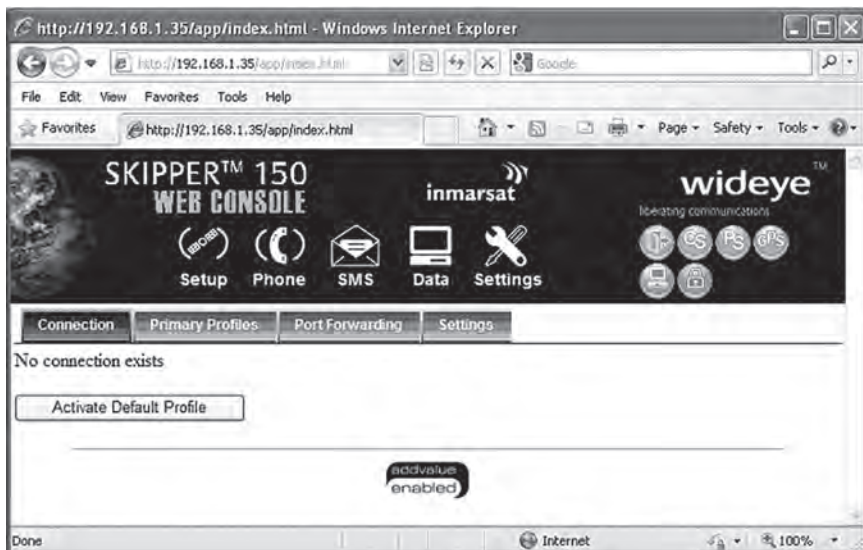

## Connection

To activate the default profile, click **Activate Default Profile**.  
The PDP context will be activated.



When connected, APN and the assigned public IP Address details will be displayed.  
You can proceed to access the Internet and use the related features.



To disconnect the data connection, click **Disconnect**.  
The PDP context will be deactivated.

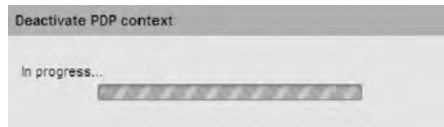

## Primary Profiles

Primary profiles define the connection type. You can select from a list of profiles to be the default primary profile and connection type. From Profile 2 to Profile 10, you can create your own customized primary profile.



**Note:**  
The Standard profile is set as the default primary profile and the default connection type is standard (this is charged by the volume [in kilobytes] of data used).

- **Profile Name**  
Change the profile name as desired.
- **Access Point Name (APN)**  
By default, the APN from the SIM will be selected.

Follow these steps to change the **Access Point Name (APN)**:

1. Select **User Defined**.
2. Enter the new APN in the field space provided (e.g. bgan.inmarsat.com).
3. Enter the username and password if required.

- **IP Configuration**  
By default, the **Dynamic IP Address** is selected.

Follow these steps to use **Static IP Address**:

1. Select **Static IP Address** and enter the IP Address in the space provided.
2. Check the **Header Compression** checkbox if it is required to use Header Compression.

## Port Forwarding

Port Forwarding is a feature for Router (multiple-user) mode. This feature sets the FB150 UE to direct incoming traffic on certain TCP/UDP port to a specific port on a local PC (IP Address).

Connection	Primary Profiles	Secondary Profiles	Port Forwarding	Settings	
Incoming Port	Protocol	Destination IP Address	Destination Port	Enabled	
0	-	0.0.0.0	0	<input checked="" type="checkbox"/>	<a href="#">Add</a>
0	-	0.0.0.0	0	<input type="checkbox"/>	<a href="#">Add</a>
0	-	0.0.0.0	0	<input checked="" type="checkbox"/>	<a href="#">Add</a>
0	-	0.0.0.0	0	<input type="checkbox"/>	<a href="#">Add</a>
0	-	0.0.0.0	0	<input checked="" type="checkbox"/>	<a href="#">Add</a>
0	-	0.0.0.0	0	<input type="checkbox"/>	<a href="#">Add</a>
0	-	0.0.0.0	0	<input checked="" type="checkbox"/>	<a href="#">Add</a>
0	-	0.0.0.0	0	<input type="checkbox"/>	<a href="#">Add</a>
0	-	0.0.0.0	0	<input checked="" type="checkbox"/>	<a href="#">Add</a>
0	-	0.0.0.0	0	<input type="checkbox"/>	<a href="#">Add</a>

Follow these steps to add a new forwarding rule:

1. Click **Add**.

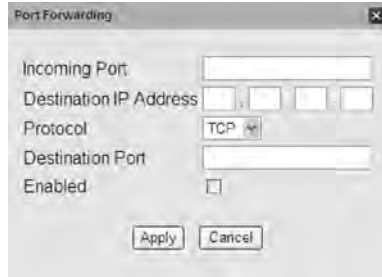

2. Enter the **Incoming Port** number in the space provided. (For example, the user expecting HTTP traffic, the port is 80).
3. Enter the **Destination IP Address**. (For example, the IP Address of the PC that is connected to the FB150 UE).
4. Select the **Protocol** type:
  - **TCP** (e.g. for HTTP, it will be TCP)
  - **UDP**
5. Enter the **Destination Port** number in the space provided (For example: listening port of the particular service (for example TCP port 80 for web server) on the PC that is connected to the FB150 UE).
6. Click **Apply** to allow the settings to take effect.

## Settings

You can select the Ethernet mode to be used for data connection.



Follow these steps to select the Ethernet mode:

1. Select the desired mode to be used during the data connection:
  - Router (Single User) is with NAT/PAT disabled.
  - Router (Multi-User) is with NAT/PAT enabled for multi-user.

**Note:**

**You can not change the Router settings while a Data connection is active, you must first disconnect your Data session.**

2. Check the **Auto Reconnect** checkbox if it is required to get the standard IP Data connection to be reconnected automatically in the event the connection is disconnected without user intervention, i.e. antenna blockage, etc.
3. Click **Update** to allow the selection to take effect.
  - Click **Refresh** to query the current mode.



## Settings Menu

Click the following tabs to view and edit the configuration settings for the FB150 UE:

- Language
- Terminal Info
- Terminal
- Ethernet
- Telephony
- PIN
- SMS
- Misc
- Support

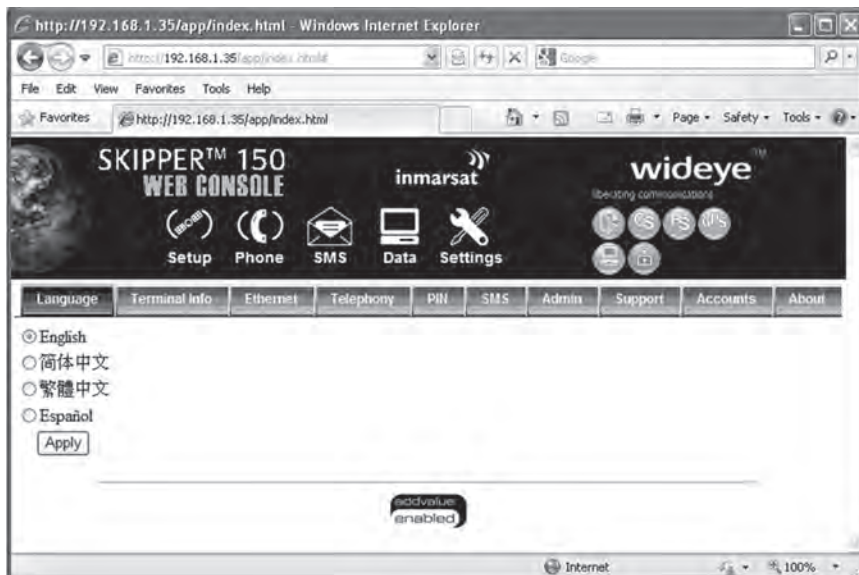

## Language

Select the desired language for the Web Console to be displayed. (Spanish, Chinese-Simplified and Chinese-Traditional may not be an option that is available at the time of purchase).



## Terminal Info

This tab shows general information about the UE, Error/Event Logs and Call Logs.

- **Information**

Displays information about the Manufacture ID, Software version, Model ID, IMEI number, IMSI number (only when a SIM card is inserted), Subscriber number and ADU serial Number.

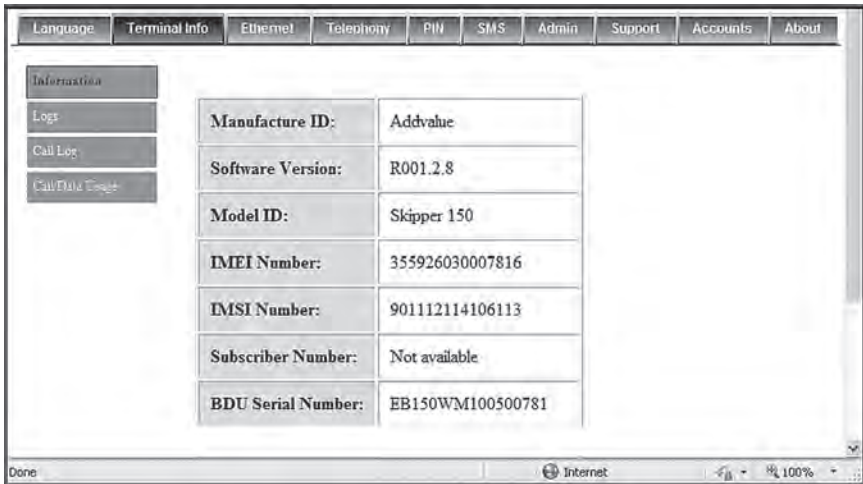



- **Logs**

Displays event and error logs of the UE.

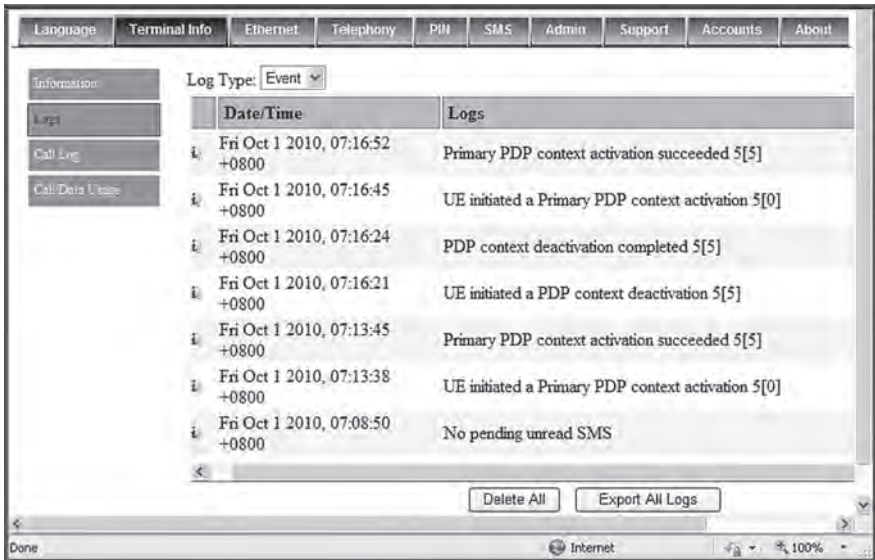

- **Call Logs**

Displays the call history including standard voice calls, high-quality/fax calls, standard data sessions and streaming data sessions.

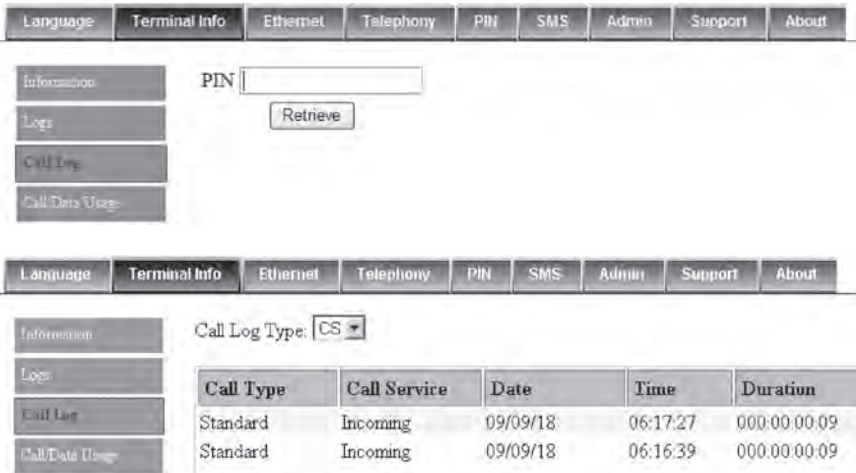

## Ethernet

- **Ethernet**

1. Click **Ethernet** to view and edit the Ethernet settings.
2. Click **Update** to allow the settings to take effect.

Language	Terminal Info	<b>Ethernet</b>	Telephony	PIN	SMS	Admin	Support	
<b>About</b>								
<hr/>								
Ethernet	Terminal IP Address:	192	.	168	.	1	.	35
DHCP	Terminal Subnet Mask:	255	.	255	.	255	.	0
Mac Filtering								<b>Update</b>

- **DHCP**

1. Click **DHCP** to view and edit the DHCP settings.
2. Click **Update** to allow the settings to take effect.

Language	Terminal Info	<b>Ethernet</b>	Telephony	PIN	SMS	Admin	Support	About
<hr/>								
Ethernet	DHCP:	<input checked="" type="radio"/> Enabled <input type="radio"/> Disabled						
DHCP	Primary DNS:	172	.	30	.	66	.	7
Mac Filtering	Secondary DNS:	172	.	30	.	34	.	7
DHCP IP Pool Start:		192	.	168	.	1	.	30
DHCP IP Pool End:		192	.	168	.	1	.	49
IP Lease Time:		60					second(s)	
							<b>Update</b>	

- **Mac Address Filtering**

1. Click **Mac Filtering** to view and edit the Mac Filtering settings.
2. Click **Update** to allow the settings to take effect.

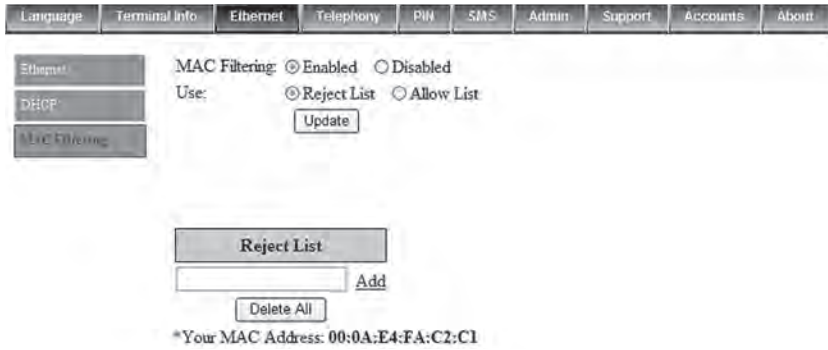

- **Reject List**

All PCs/Laptops will be allowed to access the UE except for those (MAC addresses) listed in the Reject List.

- **Allow List**

All PCs/Laptops will be denied access to the UE except for those (MAC addresses) listed in the Allow List. When selecting this list, at least one entry should be there to access the UE.

## Telephony

- **Interface**

1. Select **European Caller Line ID Phone connected** or **US Caller Line ID Phone connected** from the **Telephone Interface Configuration** drop-down menu.
2. Click **Update** to allow the setting to take effect.



- **Caller ID**

1. Click **Retrieve** to get current setting of the **Allow called party to see your number** configuration.
2. To change the setting, select **Yes**, **No**, or **According to network subscription** for the **Allow called party to see your number** configuration.
3. Click **Apply** to allow the setting to take effect.



- **Call Waiting**

1. Click **Retrieve** to get current setting of the **Enable call waiting** configuration.
2. To change the setting, select **Yes** or **No** for the **Enable call waiting** configuration.
3. Click **Apply** to allow the new setting to take effect.



- **Call Barring**

1. Click any individual **Retrieve** option to get the current setting of the corresponding scenario in which the calls would be barred.
2. Select the scenario in which the calls would be barred, or deselect the scenario to disable the corresponding call barring.
3. In the **Barring PIN** field, input a PIN for call barring setup.
4. Click **Apply** to allow the corresponding setting to take effect.
5. Clicking **Retriever All** will retrieve the current settings of all four call barring scenarios at the same time.
6. Clicking **Apply All** will allow the settings of all four call barring scenarios to take effect at the same time.

Language	Terminal Info	Ethernet	Telephony	PIN	SMS	Admin	Support	Accounts	About
Interface	<input type="checkbox"/> Bar all outgoing calls		<a href="#">Retrieve</a>	<a href="#">Apply</a>					
Caller ID	<input type="checkbox"/> Bar all outgoing international calls except those directed to the home country		<a href="#">Retrieve</a>	<a href="#">Apply</a>					
Call Waiting	<input type="checkbox"/> Bar all incoming calls when roaming outside the home country	Barring PIN:	<input type="text"/>	<a href="#">Retrieve</a>	<a href="#">Apply</a>				
Call Forwarding	<input type="checkbox"/> Bar all incoming calls		<a href="#">Retrieve</a>	<a href="#">Apply</a>					
	<input type="button" value="Retrieve All"/> <input type="button" value="Apply All"/>								

- **Call Forwarding**

1. Click any individual **Retrieve** option to get current setting of the corresponding scenario in which incoming calls would be forwarded.
2. Select the scenario in which the calls should be forwarded, or deselect the scenario to disable the corresponding call forwarding setting.
3. In the **Divert to Number** field, input the phone number where the incoming calls should be forwarded to (+<country code><telephone number>).
4. If the **Divert if not answered** option is selected, select from the **Divert After (seconds)** drop-down list, the period of time the network should wait before forwarding the calls.
5. Click **Apply** to allow the setting to take effect.
6. Clicking **Retriever All** will retrieve the current settings of all four scenarios in which the calls would be forwarded, at the same time.
7. Clicking **Apply All** will allow the settings of all four scenarios to take effect at the same time.

Language	Terminal Info	Ethernet	Telephony	PIN	SMS	Admin	Support	Accounts	About
Interface			<b>Divert To Number</b>	<b>Divert After (seconds)</b>					
Caller ID	<input type="checkbox"/> Divert all calls		<input type="text"/>			<a href="#">Retrieve</a>	<a href="#">Apply</a>		
Call Waiting	<input type="checkbox"/> Divert if busy		<input type="text"/>			<a href="#">Retrieve</a>	<a href="#">Apply</a>		
Call Barring	<input type="checkbox"/> Divert if not answered		<input type="text"/>	30		<a href="#">Retrieve</a>	<a href="#">Apply</a>		
Call Forwarding	<input type="checkbox"/> Divert if out of reach		<input type="text"/>			<a href="#">Retrieve</a>	<a href="#">Apply</a>		
	<input type="button" value="Retrieve All"/> <input type="button" value="Apply All"/>								

## PIN

- **Terminal PIN**

1. Click **Terminal PIN** to configure the Terminal PIN settings.
2. Select **Disabled** if you do not need to set the Terminal PIN.
3. Select **Enabled** to set the terminal PIN.
4. Enter the PIN number in the Enter PIN field and click **Update PIN**.

Follow these steps to change the **Terminal PIN**:

1. Enter the old PIN number in the **Enter Old PIN** field.
2. Enter the new PIN number in the **Enter New PIN** field.
3. Re-enter the new PIN number in the **Re-enter New PIN** field.
4. Click **Change PIN Password**.  
The Terminal PIN is now changed.

**NOTE:** The default **Terminal PIN** is “0000”.



- **SIM PIN**

1. Click **SIM PIN** to configure the SIM PIN settings.
2. Select **Disabled** if you do not need to set the SIM PIN.
3. Select **Enabled** to set the SIM PIN.
4. Enter the PIN number in the space provided and click **Update PIN**.

**NOTE:** The SIM PIN depends on the SIM card. Consult your equipment distributor if necessary.



- **SIM PIN2**

1. Click **SIM PIN2** to configure the SIM PIN2 settings.
2. Select **Disabled** if you do not need to set the SIM PIN2.
3. Select **Enabled** to set the SIM PIN2.
4. Enter the PIN number in the space provided and click **Update PIN**.

Follow these steps to change the **PIN Password**:

1. Enter the old PIN number in the **Enter Old PIN** field.
2. Enter the new PIN number in the **Enter New PIN** field.
3. Re-enter the new PIN number in the Re-enter New PIN field.
4. Click **Change PIN Password**.  
The Terminal PIN is now changed.

**Note:**

The **SIM PIN2** depends on the SIM card. Consult your equipment distributor if necessary.



## SMS

To change the **SMS service Center Address** number, enter the new number in the space provided and click **Update**.



**Note:**

Please contact your distributor or service provider if you do not know the Service Center Address.

## Admin

- **Change Password**

Follow these steps to change the Web Console login Password:

1. Enter the old password in the **Old Password** field.
2. Enter the new password in the **New Password** field.
3. Re-enter the new password in the **Re-type Password** field.
4. Click **Update**.

The Web Console login password is now changed.

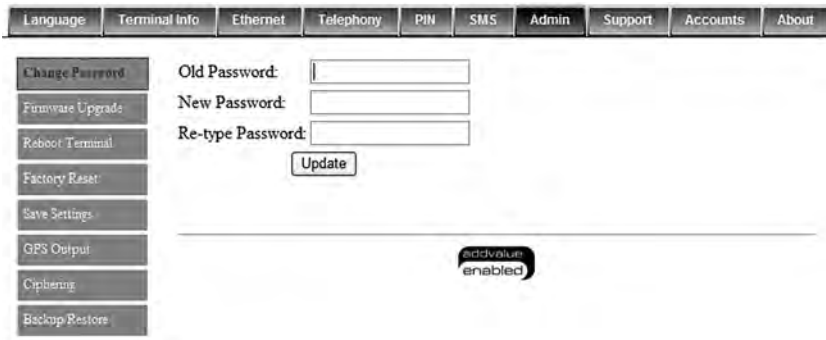

The screenshot shows the 'Admin' section of the Web Console. At the top, there is a navigation bar with tabs for Language, Terminal Info, Ethernet, Telephony, PIN, SMS, Admin, Support, Accounts, and About. Below this, a sidebar on the left contains buttons for Change Password, Firmware Upgrade, Reboot Terminal, Factory Reset, Save Settings, GPS Output, Ciphering, and Backup Restore. The main content area displays the 'Change Password' form with three input fields: 'Old Password:', 'New Password:', and 'Re-type Password:'. An 'Update' button is positioned below the 'Re-type Password' field. At the bottom of the page, there is a logo that says 'android enabled'.

- **Firmware Upgrade**

Firmware upgrade is to update your FB150 UE with the latest firmware. Please refer to your respective distributor for your firmware download.

**Warning:**

**DO NOT abort the upgrading process or unplug the power of the FB150 UE during the firmware upgrade process at any time. Doing so will corrupt the existing firmware loaded onto the FB150 UE.**

Follow these steps to upgrade the firmware for your FB150 UE:

1. Download or acquire the new firmware from your respective distributor and save it in your computer's hard drive.

**Note:**

**Make sure the FB150 UE is switched on and connected to the desktop/laptop computer using the LAN cable.**

2. Select **Firmware Upgrade**.  
Read the **Disclaimer** message carefully before proceeding with the Firmware Upgrade.



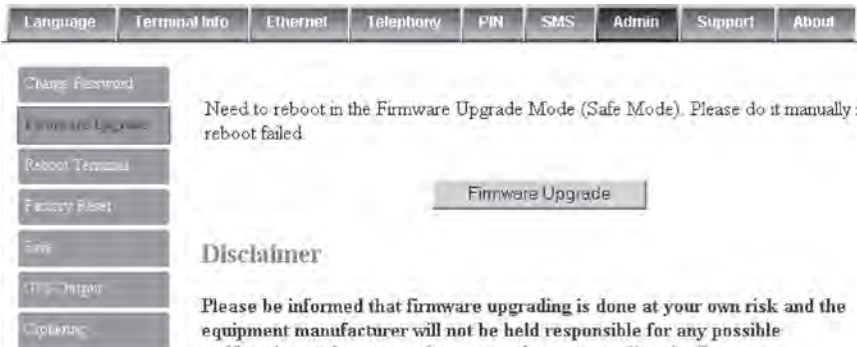

3. Click **Firmware Upgrade**.  
The FB150 UE will reboot into Safe mode.

**NOTE: All LEDs will turn to amber color and start blinking, which means it's on Safe mode.**

**Waiting for Terminal to reboot into safe mode.**

4. The FB150 Web console will appear. Re-log in using the provided username and password.

**NOTE: If the Skipper web console didn't appear, you can manually refresh the web console by clicking the F5 on your keyboard.**

Username:  skipper value enabled  
Password:  skipper value enabled

- Browse to the location of the new firmware, select, and click **Upload**.



- Firmware upgrade will take approximately 10 to 12 minutes to complete. You will be prompted with the **Result: Firmware Upgrade Completed** message.

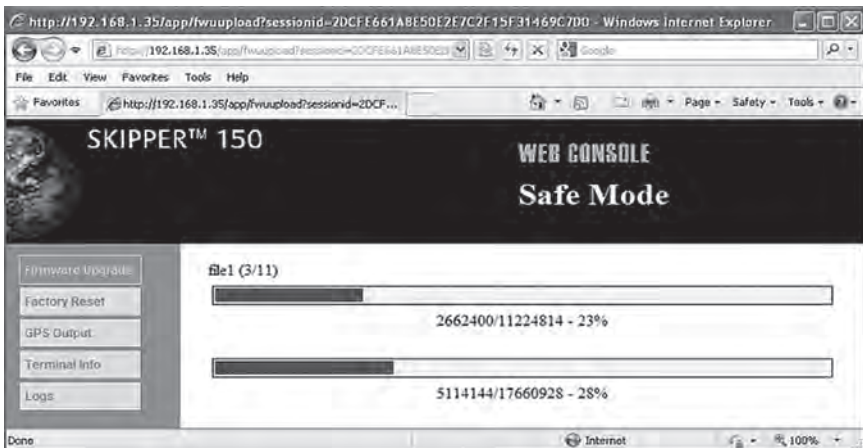

7. Click **Reboot Terminal** to reboot the FB150 UE.

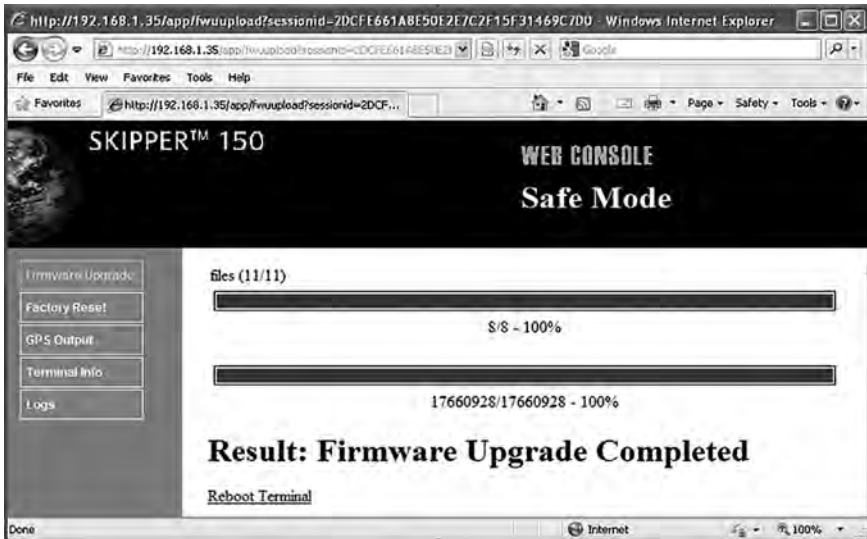

- **Reboot Terminal**

If you wish to reboot the FB150 UE, click **Reboot Terminal**. Click **Reboot** and wait for a few minutes to allow the UE to reboot. Refresh your browser to update the Web Console page after reboot.

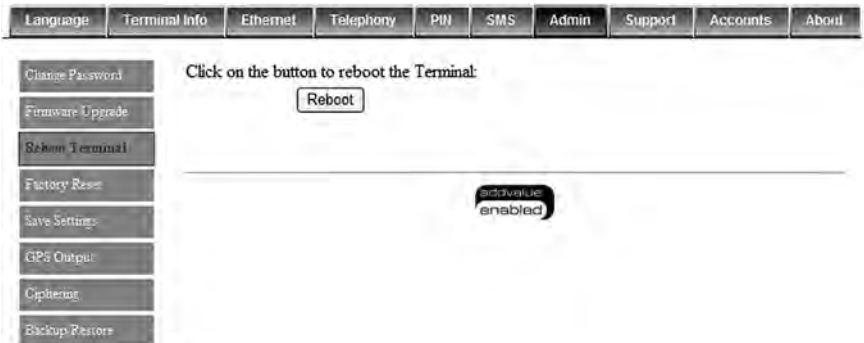

- **Factory Reset**

To perform a Factory Reset, enter the Security code **0000** and click **Factory Reset**.

**Warning:**

All the settings and user data (e.g., Phone Book, GPS, etc.) of the FB150 UE will be cleared and reset to the default settings. If you do not wish to lose critical user data such as Phone Book, please use limited reset option available via Primary Handset.

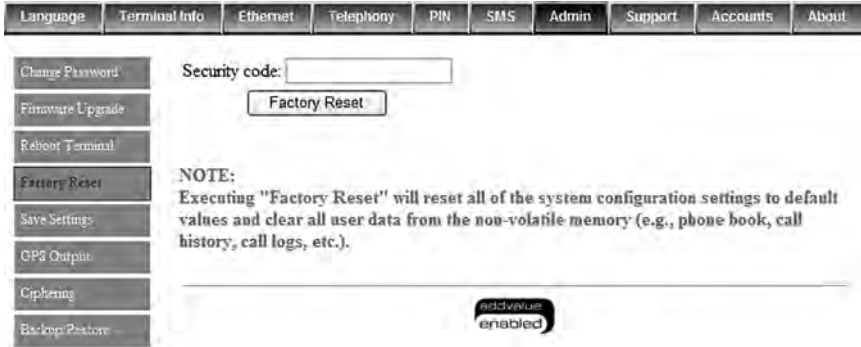

- **Save Settings**

To power down the FB150 UE BDU using the main power switch, it is recommended to save the recent setting changes. To save the recent changes, click **Save Now**.

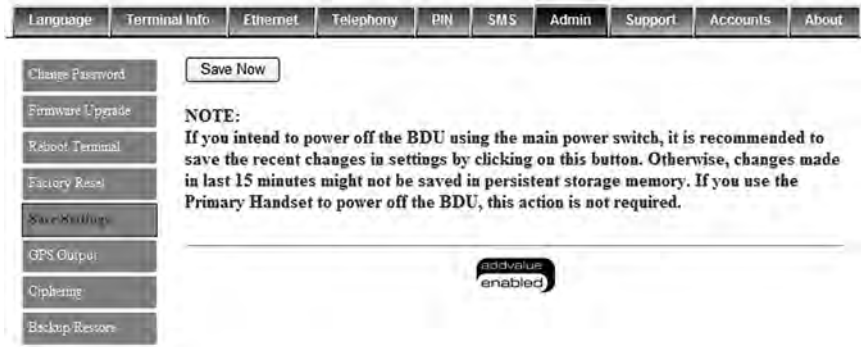

- **GPS Output**

By default, FB150 UE BDU outputs the GPS data in NMEA format (at 9600bps) via the **NMEA 0183 Connector for GPS output**. For technician who wants to diagnose the system, he/she may collect the debug log messages by selecting **Output Debug Log**. Since the debug mode is not required for normal users, it is recommended not to make any changes to this setting.



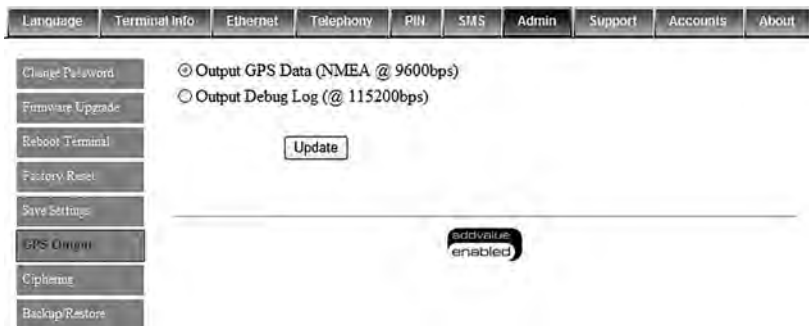

- **Cipherng**

Enabling the **Cipherng** option will make the FB150 UE to exchange voice and data in secure mode by encrypting them over the air. To enable/disable the **Cipherng**, select the option **Enabled** or **Disabled** respectively and click **Update** to make the change to take effect.

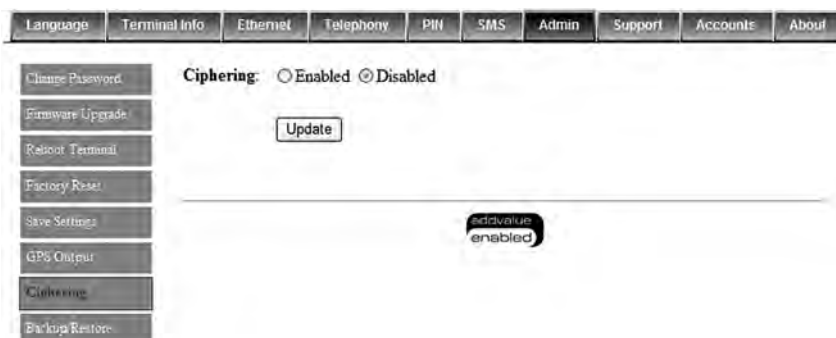

- **Backup / Restore**

Allows the user to make Full backup / Partial backup and Restore the system configuration.

To backup, select option **Full backup** or **Partial backup** and click **Backup**.

**Note: Full backup:** can only restore on the same terminal.

**Partial backup:** able to restore on another terminal of the same model and Firmware version.

To restore, click **Browse** to select the location of the backup file and click **Restore**.

Language	Terminal Info	Ethernet	Telephony	PIN	SMS	Admin	Support	Accounts	About
----------	---------------	----------	-----------	-----	-----	-------	---------	----------	-------

Change Password	<b>Backup:</b> <input checked="" type="radio"/> Full backup (can only be restore on the same Terminal) <input type="radio"/> Partial backup (able to restore on another Terminal of the same Model and Firmware version)
Firmware Upgrade	
Select Terminal	
Factory Reset	
Send Backup	
OPN Output	
Helpdesk	
Backup Status	

**Restore:**

Backup package:

---

## Support

Display information of the support telephone number, support email address, Support URL and Services URL. (The information shown are for sample purpose only.)

Language	Terminal Info	Ethernet	Telephony	PIN	SMS	Admin	Support
----------	---------------	----------	-----------	-----	-----	-------	---------

<b>Inmarsat Distribution Partner Name:</b>	Fleet Test Cards
<b>Phone Number For Support:</b>	<a href="tel:+442077281653">+442077281653</a>
<b>Support E-Mail Address:</b>	<a href="mailto:bgantest1@inmarsat.com">bgantest1@inmarsat.com</a>
<b>Support URL:</b>	<a href="http://support.inmarsat.com/nmm1.aspx">http://support.inmarsat.com/nmm1.aspx</a>
<b>Services URL:</b>	<a href="http://support.inmarsat.com/nmm2.aspx">http://support.inmarsat.com/nmm2.aspx</a>

## Accounts

Add / delete multiple user accounts for Web console access with configurable access rights.

To add a new user, click **Add** and enter the name of the user.

To delete user, click **Delete**.

To change password per user, highlight the user name and click **Change Password**.



To configure access rights, select **View Only** or **Full Access** required for the user by checking the box. Check the box for the required permission.

**View Only:** allows the user for viewing only or read only.

**Full Access:** allows the user full control to change and save settings on the terminal.

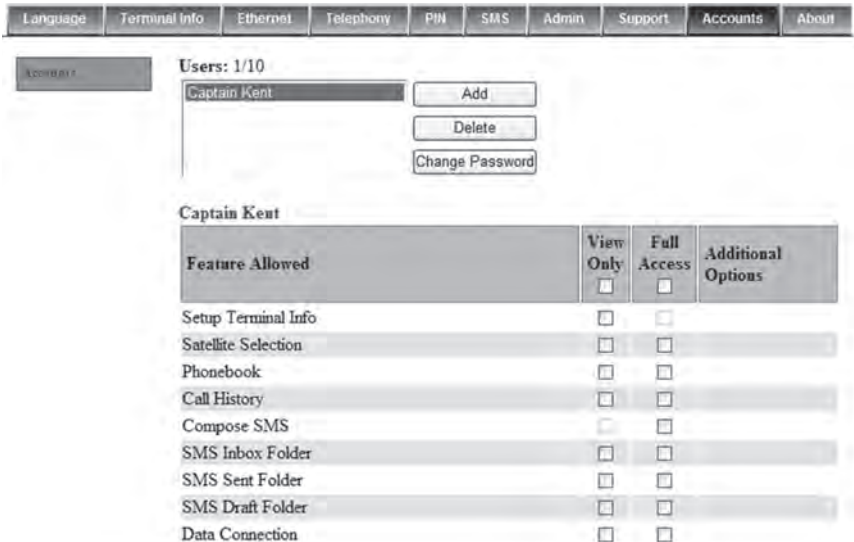

# Chapter5

## Connecting Devices with SKIPPER™ 150 UE

### Available interfaces

There are multiple connectors available on the SKIPPER™ 150 UE, meant for connecting to four different types of devices:

1. Standard Analog Corded or Cordless Phone
2. Primary Handset for voice calls
3. LAN connection for standard PC and/or Network data connection
4. NMEA 0183 connector for GPS output



#### (1) Standard analog phone

The BDU has a dedicated connector (RJ11) for connecting to a standard analog phone.

#### (2) Primary Handset

The BDU has a dedicated handset connector (RJ45) for connecting the Primary Handset.

#### Note:

**The Primary Handset must only be connected to the dedicated HANDSET (Model Name: FB150-PH) connector on the BDU.**

#### (3) RJ45 Ethernet LAN (PoE) Port for DATA

The BDU has one Ethernet (LAN) connector (RJ45) supporting the Power over Ethernet (PoE).

#### (4) NMEA 0183 Connection for GPS output

Requires an optional GPS cable with BDU connector on one end and a standard RS-232 DB9 connector on the other end, available from your Addvalue dealer.



## IP 44 Protection

The SKIPPER™ 150 BDU meets or exceeds IP 44 requirements for environmental protection, i.e. dust and water, provided the UE is used with the included RJ11 phone cord, RJ45 LAN cable and the Primary Handset. To maintain proper environmental protection, care should be taken to ensure that the cables are connected so that the connector “lip” fits over the raised edge surrounding the corresponding port.

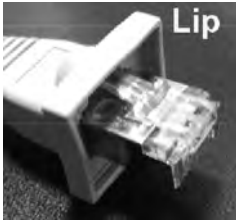

## Connecting To A Computer

To connect a computer to the SKIPPER™ 150 BDU you need a LAN (Category 5) Cable.

1. Plug one end of the LAN cable to a PoE RJ-45 port meant for DATA and the other end to your computer network port.
2. Use the Web Console as listed in the **Data Menu** section of Chapter 4 - Using the Web Console, to configure the SKIPPER™ 150 BDU and activate a data connection.



### **WARNING:**

**Do NOT plug any LAN cable other than approved handset cable into the BDU's handset port. Doing so will damage that port.**

## Using A Standard Phone

You can connect a standard analog corded or cordless phone to the **PHONE** port using the included IP44 rated RJ11 phone cable to make and receive voice calls.

When there is an incoming standard voice call, all the phones connected to those ports will ring. Once one of them answers the call, all other phones will stop ringing.

# Chapter6

## Installation of ADU

### Installation of ADU with Antenna Cable

The position of the ADU has to be kept away from the beam width of any search or tracking radar, which transmits radiating power, as well as from the radiations of HF/ VHF antennas. In addition, a safety compass distance is also to be taken into account.

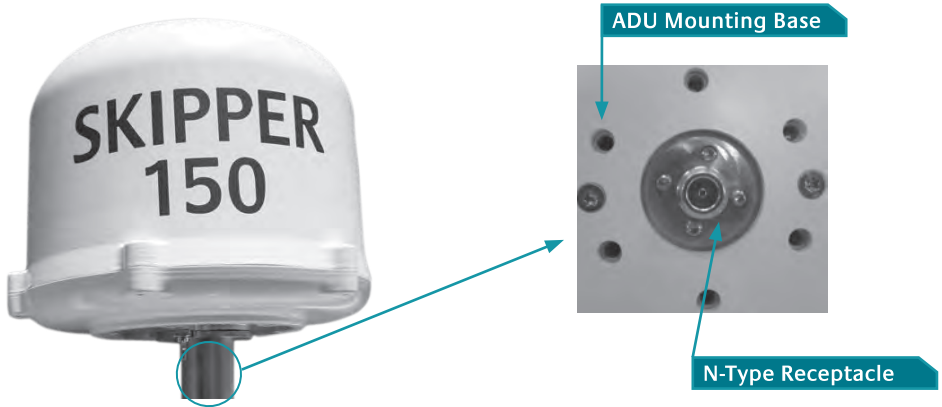

### Important notes to be followed before installing ADU

The following notes shall be observed:

1. The position of the ADU has to be kept away from the beam width of any search or tracking radar, which transmits radiating power.

With reference to the illustration, there are recommended mounting positions of the ADU where they are kept away from the red region area of the beam width. This way, the ADU will not be interfered by any transmitting radar. The angle of radar beam width normally ranges from  $10^{\circ}$  to  $25^{\circ}$  degrees with respect to the centre of the radar arm. However, it is worthwhile to check its manufacture's technical specification.



2. The position of the ADU especially its line of sight to a satellite shall not be obstructed by any large obstacle in a vessel or ship. This will result in the degradation of the satellite signal.

Examples of the large obstacles are as follow:

- Upper deck and funnel of ship



- VSAT with its radome



- Large mechanical structure mounting of any radar



3. For the safety reason, all personnel have to keep away at least 1-meter from the ADU.

## Connecting Antenna Cable

There is a coaxial connector at the base centre of the ADU where it is a N-type receptacle connector. The antenna cable terminated with N-type plug connector is to be inserted into the ADU first before proceeding to the installation of the ADU.

It is highly recommended to protect the coaxial connector by applying water-proof insulation tape to protect it due to humidity conditions.

## Mounting of ADU

The mounting of the ADU depends on the structure of the vessel or ship. It can be mounted on either on long post or antenna mast (if available on the ship) as long as it is free of any shock or vibration.

## Mounting of ADU on Antenna Mast

The requirements of the antenna mast are as follow:

- The physical size of the mast shall support the weight of ADU at 2.5kg and the physical dimension of Ø278mm with height of 228mm. An example of the antenna mast is illustrated as below.



Antenna Mast

- The mast should provide the internal hole for the installation of the antenna cable.
- The flange (known as the top plate) of the mast shall meet the dimensions of the ADU's mounting base, where there are 6 holes.
- The rubber gasket is required to be inserted between the ADU mounting base and the flange.

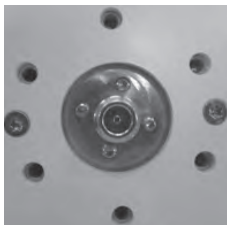

ADU Mounting Base

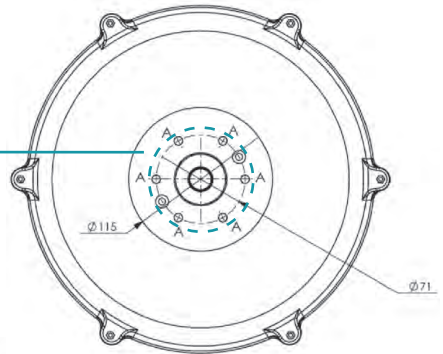

Clearance holes for M6  
(Recommended  $>\phi 6.5\text{mm}$ )

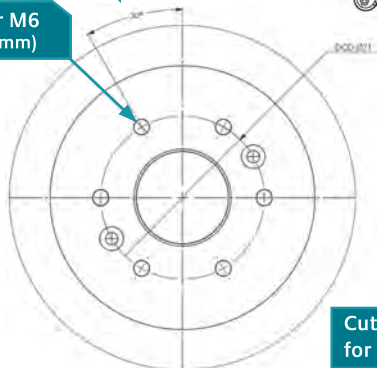

A : Use M6x20 Hex Head Screw bolts (6x) into the threaded holes of ADU Mounting Base for mounting the ADU.

Cut-hole Dimension for flange

**Note:** In case of the existing mast's flange in a vessel or ship does not fit the ADU's mounting base's holes, a custom-made mechanical adaptation flange is to be designed and plate, which acts as an interface between the existing mast and the ADU.



Custom-made mechanical adaptation flange

### Mounting of ADU on Long Pole

The physical dimension of a long pole shall be preferably at 2 meter height with its diameter ranges from Ø35 to Ø 50mm. In addition, the standard pole mount kit must be used for the installation of the ADU onto the long post.



- (1) Long Post
- (2) Pole Mount
- (3) Coaxial Antenna Cable

The standard pole mount kit includes the detailed installation guide.

# Chapter7

## Installation of BDU

### Installation of BDU

An overview of BDU's basic connections with Primary Handset cable, power cable and antenna coaxial cable is illustrated as below.

#### ADU

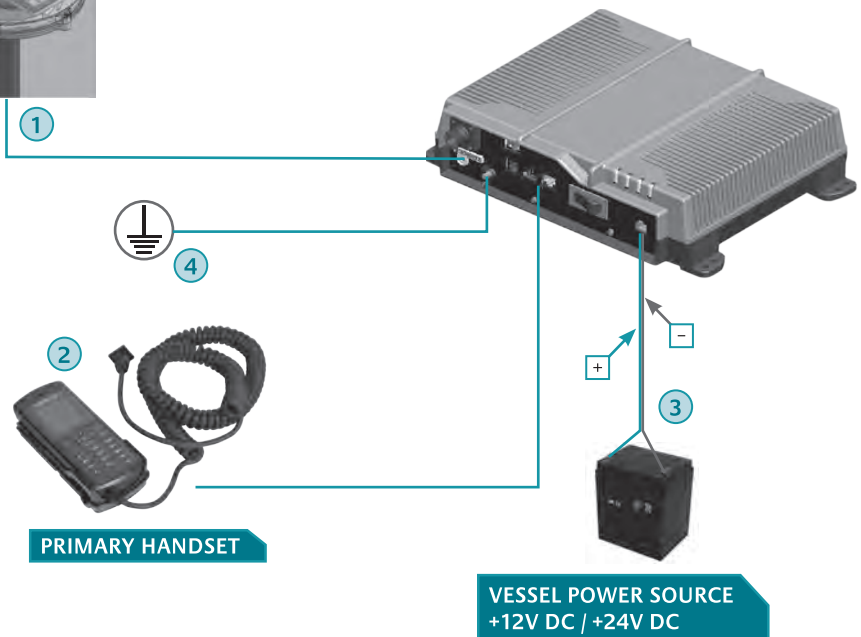

- (1) Antenna Cable
- (2) Primary Handset Cable
- (3) DC Power (1.8-meter) Cable
- (4) Grounding Cable\*

#### Note:

\* Grounding cable shall be connected to a vessel's hull as the earth / grounding point. It is not included in the standard accessories.

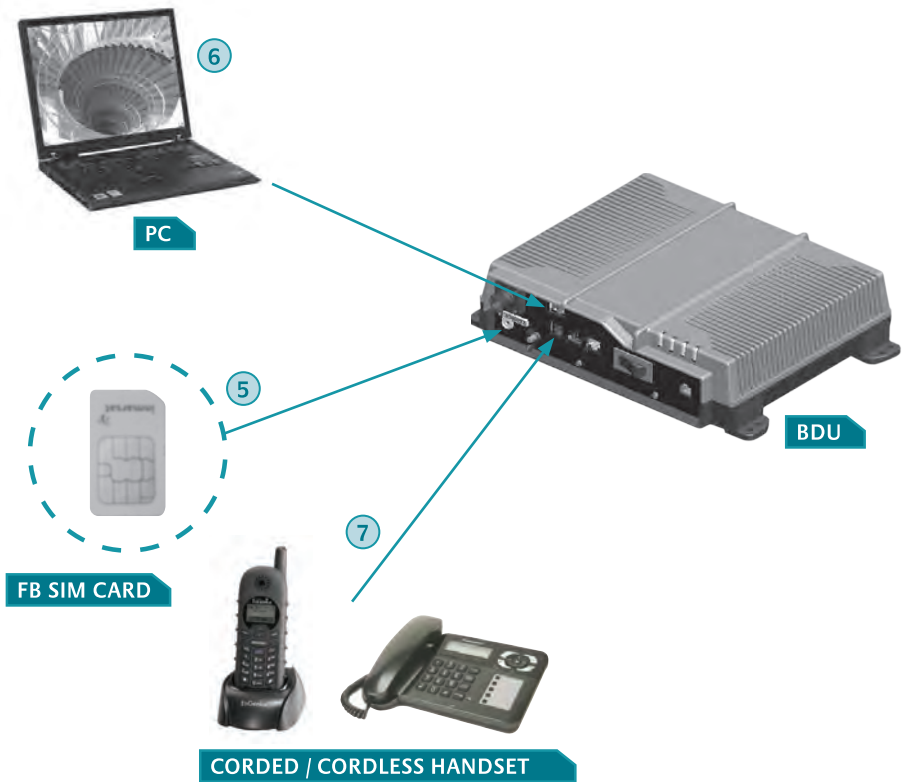

- (5) FB SIM Card
- (6) RJ45 Category 5 Network (1.5-meter) Cable
- (7) RJ11 Telephone Cord (1.8-meter) Cable

## Important notes to be followed before installing BDU

The following notes shall be noted:

1. The BDU shall be placed in any room, mostly a bridge of a vessel, where its ambient temperature ranges from  $-25^{\circ}\text{C}$  to  $+55^{\circ}\text{C}$ .
2. The desktop or the wall surface shall support the dimension and weight of 297 x 228 x 77 mm and 2.8kg respectively.
3. The BDU shall be placed away from a high-vibrated engine as far as possible.



## Mounting of BDU

The BDU can be installed in different ways:

- On the desktop
- On the wall surface or top ceiling
- Under captain's console

### BDU in Desktop Installation

The BDU can be placed on the table or desktop. It has its four rubber feet which are attached to the base of the BDU, which it can rest on any desktop or even table. The rubber feet can prevent the BDU from being shaken or moveable.

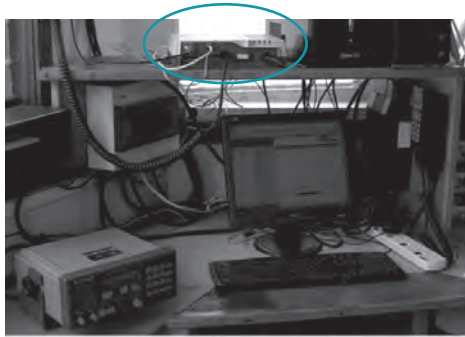

### BDU on Wall / Top Ceiling Installation

The BDU can be mounted on the wall surface by means of using 4 pieces of C-clips with the mounting kits. The mounting kits includes M6 hexagon screws, spring washers and nut to attach the C-clips into the mounting legs securely.

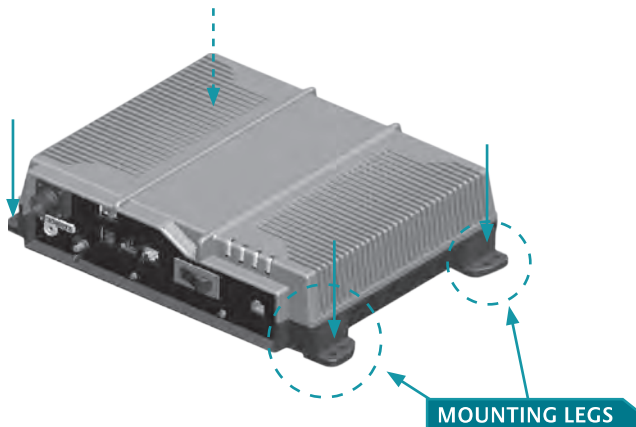

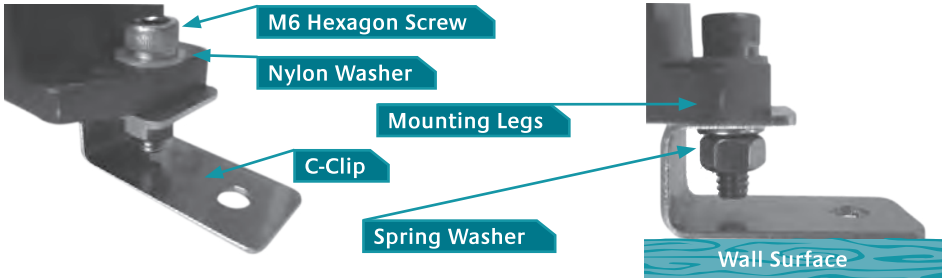

**Note:**

\* C-clip mounting kit consists of C-clip, nylon washer, spring washer, hexagon screw and nut. This mounting kit is not included in the standard accessories.

### Connecting power cable to BDU



The DC input to the BDU can be supplied by:

- Vessel's +24V DC, 10A power supply directly
- Vessel's +12V batteries connected in series as +24V DC direct power supply directly
- Vessel's direct +12V battery with high ampere-hour
- Vessel's universal AC input range of 85-264V AC provides direct +24V DC output via AC/DC power supply\*

**\* Note:** During the BDU's power up, there is an initial high surge current. For this reason, the AC/DC power supply with the single output of +24V DC with 10A or higher current capability is strongly recommended.

It is important that the first step is to connect the power cable to the vessel's power with the color code of wiring. On the front panel of BDU, there is an indication of (+) and (-) above the 2-pin green, phoenix power socket.

The 1.8-meter DC power plug cable includes red and black wires.

- Red Wire shall connect to green power socket (+)
- Black Wire shall connect to green power socket (-)

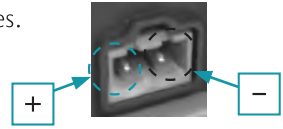

The power plug cable is inserted to the front panel's power socket. A white power switch\*, which is situated next to the power socket, is catered for an user to turn on.

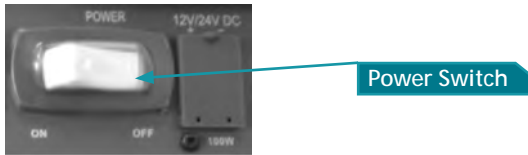

**\* Note: The white power switch combines its internal 12A circuit breaker and ON/OFF switch with rocker actuation. Thus, the power switch protects the terminal against any overcurrent or short-circuits.**

## Connecting Antenna Cable to BDU

The ADU has included 10-meter antenna cable.

The antenna has 2 different type of connectors which are both terminated at each end; TNC (Male) and N-type (Male) respectively.

The N-type terminated at the end of antenna cable is catered for its connection to the ADU.



Plug the TNC(Male) at the other end of the antenna cable into the BDU's antenna connector, which is TNC (Female).

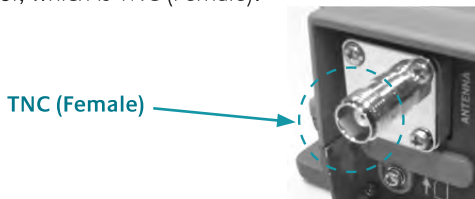

## 1-meter Pigtail Antenna Cable

For any user who intends to use the existing antenna cable terminated with both N-type connectors on the vessel and the cable is long with its large diameter, then 1-meter pigtail antenna is an optional accessory and it is highly recommended to be used.

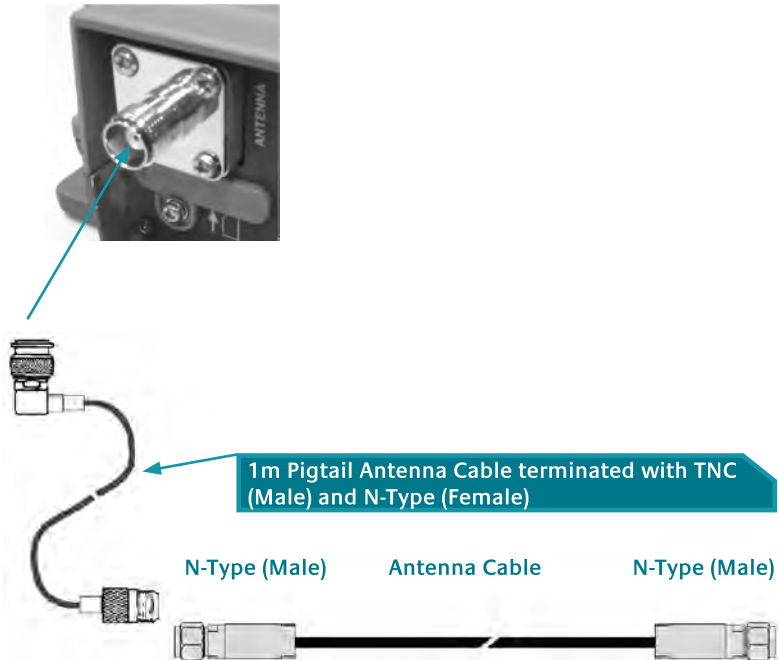

## Antenna Cable

If there is a need to have a different cable other than 10-meter antenna cable, it is important that an antenna cable shall meet the requirement especially in the RF attenuation. The maximum attenuation in the antenna cable must be less than 12 dB at the frequency of 1600 MHz to ensure the performance of the system.

### Recommended antenna cables

The below table recommends antenna cable types with their respectively attenuation (dB/100m) and maximum cable length.

Antenna Cable	Diameter (mm)	Loss @ 1.6 GHz (dB/100m)	Max Cable Length (m)
Suhner RG223/U	φ 5.4	60.5	18
Belden RG8/U	φ 10.2	19.1	50
SSB-Electronic Ecoflex 15	φ 14.6	13.1	80
Suhner S10162B11	φ 12.9	12.0	90
RFS-LCF12-50J	φ 16.2	9.6	110
Times Microwave LMR-400	φ 10.2	17.4	68
Times Microwave LMR-600	φ 14.9	11.2	106

# Chapter8

## Troubleshooting and FAQs

### 1. LEDs Signalling

#### General LED status



#### Terminal LED

Status	Descriptions / Remedial Actions
RED	<ul style="list-style-type: none"><li>• Reboot the terminal.</li><li>• Reboot the terminal in Safe Mode and perform firmware upgrade using the latest firmware release.</li></ul>

#### Registered LED

Status	Descriptions / Remedial Actions
RED	<ul style="list-style-type: none"><li>• Ensure a correct Inmarsat FleetBroadband (FB) SIM Card is used for network registration.</li><li>• Ensure that there is no schedule BGAN network outage.</li></ul>
AMBER (Blinking Faster)	<ul style="list-style-type: none"><li>• Attempting network registration.</li></ul>

#### Antenna LED

Status	Descriptions / Remedial Actions
RED	<ul style="list-style-type: none"><li>• Ensure a correct type of antenna cable as per Addvalue's recommended list and the length of the cable does not exceed the maximum length, depending on the type of the antenna cable.</li><li>• Ensure RF Connection at both antenna and terminal are properly secured.</li><li>• Ensure a correct DC power supply of +24V DC with high current capability ( at least 10A ) is used.</li></ul>

#### GPS LED

Status	Descriptions / Remedial Actions
RED	<ul style="list-style-type: none"><li>• No GPS Response (GPS Error).</li></ul>

## 2. FB SIM Card

Symptoms	Descriptions / Remedial Actions
SIM Card cannot be detected by terminal	<ul style="list-style-type: none"><li>• Ensure that a correct Inmarsat FleetBroadband (FB) SIM card is used.</li><li>• Ensure that a FB SIM card is properly inserted into SIM Card Slot.</li><li>• Retry by re-inserting the FB SIM card into SIM Card Slot before powering up the terminal.</li></ul>
Terminal indicates “Wrong SIM Card”	<ul style="list-style-type: none"><li>• Ensure that a correct Inmarsat FleetBroadband (FB) SIM card is used.</li></ul>

## 3. GPS

Symptoms	Descriptions / Remedial Actions
Unable to acquire GPS even after a long time	<ul style="list-style-type: none"><li>• Ensure that there is no blockage for the antenna.</li></ul>
No NMEA string output from the GPS port	<ul style="list-style-type: none"><li>• Ensure that GPS LED is not RED.</li><li>• Ensure that there is a proper connection at the GPS port.</li><li>• Ensure that the GPS output is set to Output NMEA data via the Web Console.</li></ul>

## 4. PoE LAN Port (RJ45)

Symptoms	Descriptions / Remedial Actions
No LAN indication	<ul style="list-style-type: none"><li>• Ensure that the Ethernet Cable is plugged into the PoE port correct.</li><li>• Check to ensure that the Ethernet Port on your PC / Laptop is working.</li><li>• Ensure that a correct type of Ethernet cable (not crossover cable) is used.</li></ul>
Unable to acquire IP address. My PC shows “Limited connectivity”	<ul style="list-style-type: none"><li>• Try to unplug and plug the Ethernet Cable.</li><li>• Try to reboot the terminal.</li><li>• Try to restart your PC/Laptop.</li></ul>
Unable to ping my terminal	<ul style="list-style-type: none"><li>• Ensure that the LAN indication LED is active.</li><li>• Ensure that the IP address of the terminal is set correctly.</li><li>• Make sure that there is no firewall or proxy settings in your PC/ laptop that prevent access to the terminal.</li></ul>

## 5. RJ11 Phone Port for Standard Call

Symptoms	Descriptions / Remedial Actions
Unable to make outgoing call	<ul style="list-style-type: none"> <li>• Make sure that there is a dial tone before making the call.</li> </ul> <p>For the case of busy tone,</p> <ul style="list-style-type: none"> <li>• Ensure that the line is not engaged by any other telephone services.</li> <li>• Ensure that all other telephony devices are hung up properly.</li> </ul> <p>For the case of no dial tone,</p> <ul style="list-style-type: none"> <li>• Ensure that the phone line is connected to the phone port of the terminal.</li> </ul> <ul style="list-style-type: none"> <li>• Make sure that a correct call number is used and with '00' prefix and ended with '#' to complete the dial number (i.e. 00870772101234#).</li> <li>• Hang up and retry the call again.</li> </ul>
Unable to receive incoming call	<ul style="list-style-type: none"> <li>• Ensure that a correct call number is used.</li> <li>• Ensure that the line is not engaged by any other telephony devices.</li> <li>• Ensure that all other telephony devices are hung up properly.</li> </ul>
Distorted audio during outgoing/incoming call	<ul style="list-style-type: none"> <li>• The audio may clip when use with some phones in high volume. Please lower the volume of the phone in such situation.</li> <li>• Please temporary disconnect any data connection since high throughput may affect the quality of the audio.</li> <li>• Hang up and retry the call again.</li> </ul>



## 6. Primary Handset

Symptoms	Descriptions / Remedial Actions
No display / power for Primary handset	<ul style="list-style-type: none"><li>• Check the DC power supply input to the terminal.</li><li>• Check the primary handset whether it is inserted to the correct handset port with connection holder.</li></ul>
Unable to connect to the terminal	<ul style="list-style-type: none"><li>• Ensure the primary handset is inserted to the correct handset port with connection holder.</li></ul>
Unable to make outgoing call	<ul style="list-style-type: none"><li>• Ensure a correct call number to be dialed.</li><li>• Hang up the handset and retry the call.</li></ul>
Unable to receive incoming call	<ul style="list-style-type: none"><li>• Ensure a correct call number is used.</li><li>• Ensure that the line is not engaged by any other telephony devices.</li><li>• Ensure all other telephony devices are hung up properly.</li></ul>
No audio during incoming/ outgoing call	<ul style="list-style-type: none"><li>• Ensure that no standard LAN cable is inserted into handset port as this causes Pins 1 and 10 of the handset port to be deformed. This results in no audio in the primary handset.</li><li>• Ensure the Primary Handset is inserted into the correct port and secured with the latch.</li><li>• Hang up and retry the call again.</li></ul>
Distorted audio during incoming/ outgoing call	<ul style="list-style-type: none"><li>• Lower the volume of the Primary Handset.</li><li>• Do temporary disconnect any background data connection since high throughput may affect the quality of the audio.</li><li>• Hang up and retry the call.</li></ul>

## 7. Web Console

Symptoms	Descriptions / Remedial Actions
Unable to access Web Console	<ul style="list-style-type: none"><li>• Ensure there is no problem with the Ethernet connectivity.</li><li>• Ensure that IP address is entered correctly.</li></ul>
Unable to login	<ul style="list-style-type: none"><li>• Ensure to use correct username and password.</li><li>• Ensure that you do not have maximum Web Console sessions being opened.</li><li>• Retry by closing and reopening the web browser.</li></ul>
Web page does not seem to be updated or there are unexpected errors occurred	<ul style="list-style-type: none"><li>• Refresh the web page.</li></ul>

## 8. Data Connection

Symptoms	Descriptions / Remedial Actions
Unable to activate Primary PDP context	<ul style="list-style-type: none"><li>• Ensure you are using a valid APN.</li><li>• For static IP connection, please make sure that your user name and password are correct.</li><li>• Ensure your FB SIM card supports PS services.</li></ul>
Unable to access internet after successfully Primary PDP context activation	<ul style="list-style-type: none"><li>• Make sure that your PC/laptop is using dynamic IP assignment or a correct gateway should be specified if using static IP.</li><li>• Make sure that there is no firewall or proxy settings in your PC/laptop that prevent access to the terminal.</li></ul>
“Auto Connect (Last successfully Activated PDP Context)” feature is not working	<ul style="list-style-type: none"><li>• Make sure that this feature is enabled via Web Console.</li><li>• A standard background connection has to be successfully activated for the first time after enabling this feature.</li><li>• This feature takes no effect if last activated PDP context is of streaming class or current data connection is terminated by the user.</li><li>• Please wait for at least 1 minute for re-connection if any error happened during connection time.</li></ul>

## 9. Safe Mode and Firmware Upgrade

Symptoms	Descriptions / Remedial Actions
Unable to enter safe mode. Terminal continues to start in normal mode	<ul style="list-style-type: none"><li>• Make sure that the safe mode button (the button besides the SIM card slot) is pressed and held tightly until all LEDs turn into amber colour.</li></ul>
Firmware upgrade fails	<ul style="list-style-type: none"><li>• Make sure that you are using the correct firmware upgrade package.</li><li>• Make sure that there is no interruption of power supply during firmware upgrade.</li><li>• Retry firmware upgrade.</li></ul>

## 10. Antenna / Satellite Signal Level

Symptoms	Descriptions / Remedial Actions
Signal Strength is low or too low ( less than 45dBHz )	<ul style="list-style-type: none"><li>• Check any obstruction such as the hull or monkey bridge of the vessel that may block the ADU's line of sight.</li><li>• Check any interference signal from the antennas that are closed to the antenna.</li><li>• Depending on the antenna's location on the vessel, the vessel's route may cause the ADU's line of sight to be blocked any structure of the vessel, depending on the elevation of the satellite.</li></ul>

## 11. Antenna' search for Satellite Signal

Symptoms	Descriptions / Remedial Actions
Antenna keeps searching for satellite continuously	<ul style="list-style-type: none"><li>• Check that the sky/satellite view of ADU is not blocked.</li><li>• Wait a little bit longer. A FB terminal has to scan through the three I-4 satellites (Americans, EMEA and Asia- Pacific) one by one to look for BGAN signal to operate on. Depend on location of vessel, this process can take as long as 6 minutes.</li><li>• Check that the FB terminal is NOT configured to lock to a particular I-4 satellite (Manual Satellite Selection) that can't be seen (by ADU) at current location.</li></ul>

## 12. Antenna's movement

Symptoms	Descriptions / Remedial Actions
Antenna does not move or rotate	<ul style="list-style-type: none"><li>• Check the BDU is powered up by looking the LEDs, which are green.</li><li>• Check the output voltage at the antenna connector at the BDU is +43V.</li></ul>

## 13. System fails to power up

Symptoms	Descriptions / Remedial Actions
No light appear on Terminal LED	<ul style="list-style-type: none"><li>• Check to ensure that the input DC power will have at least +24V DC, 10A or +12V DC, 20A.</li><li>• Check to ensure the circuit breaker at the panel is fully depressed at "ON" position.</li></ul>

# Appendix A

## Technical Specifications

### A.1 BDU's Outline Dimensions

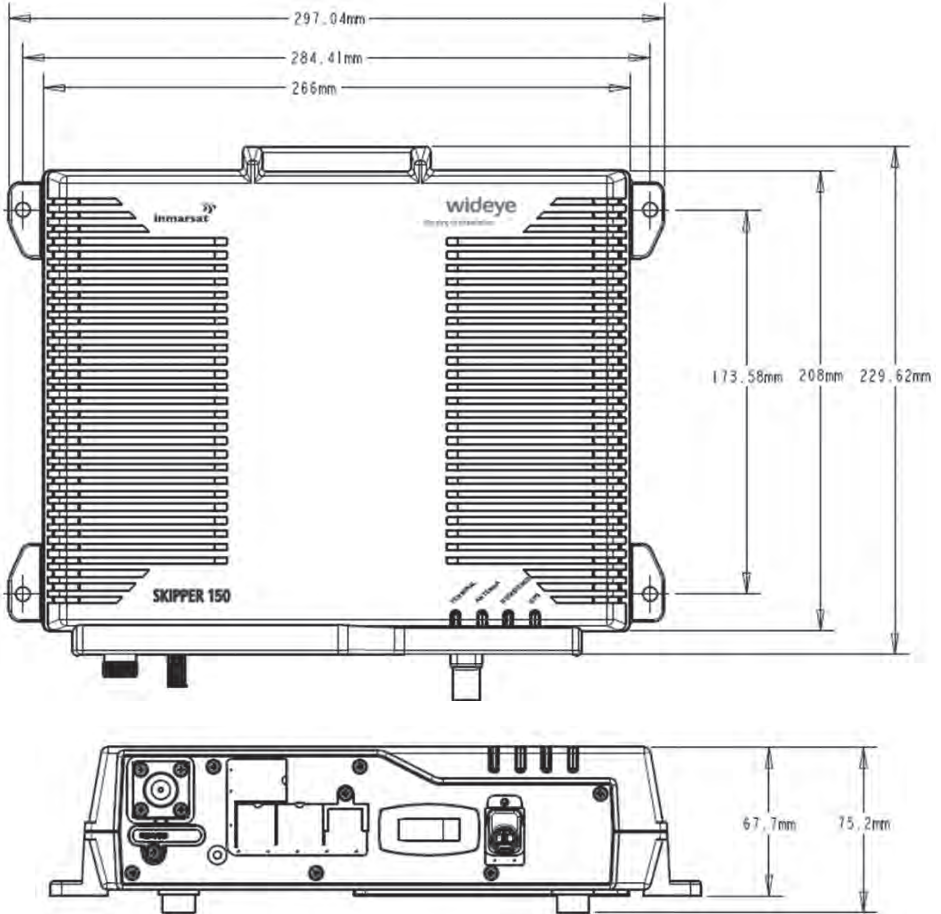

## A.2 ADU's Outline Dimensions

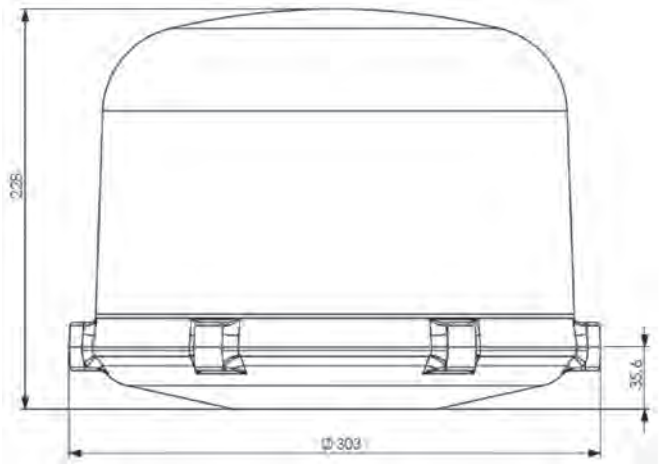
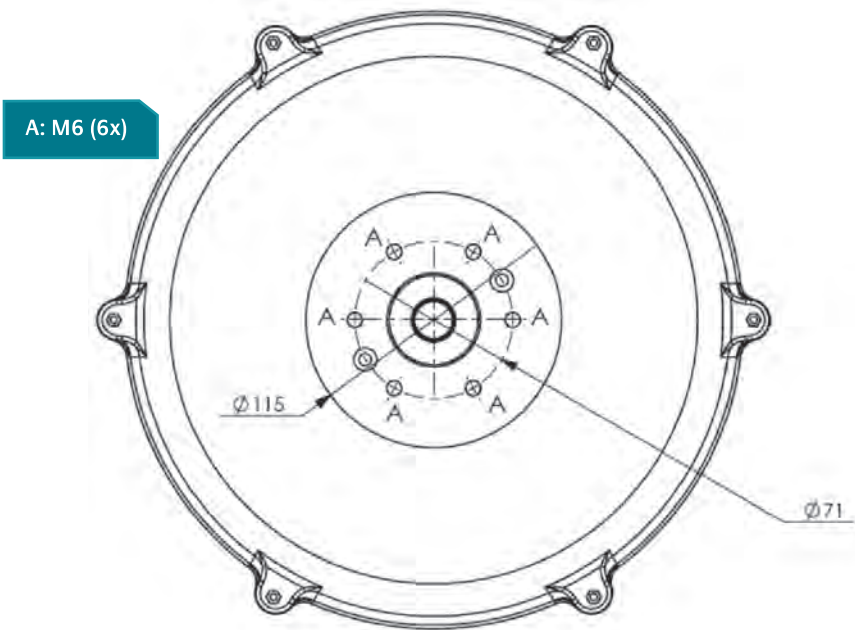

**Weight: 2 kg**  
Dimensions are expressed in terms of mm.

### A.3 ADU's Hole Pattern (Cut-out Holes)

